

Full extension rails, 3-level, Stainless steel
Z11TF36X0

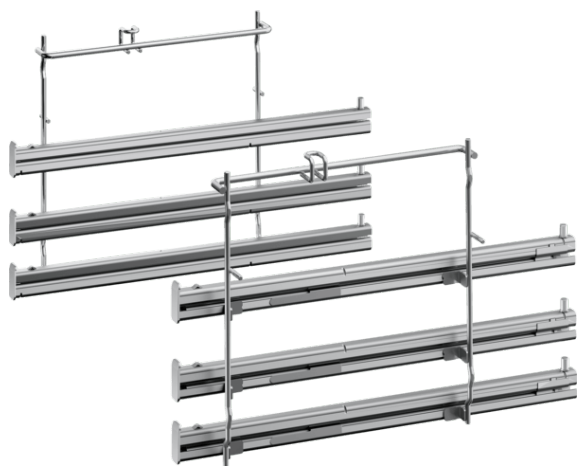

COOKING PASSION SINCE 1877



Features

Technical Data

Dimensions of the packed product (HxWxD) (mm) : 90 x 410 x 305

Pallet dimensions : 100.0 x 80.0 x 120.0

Standard number of units per pallet : 50

Net weight (kg) : 2.893

Gross weight (kg) : 3.2

EAN code : 4242004182863



Full extension rails, 3-level, Stainless steel
Z11TF36X0

Features

- With the telescopic rails on level 1, 2 and 3 the accessories glide out of the oven with ease.