

WINE CELLAR

WKb 1712



LIEBHERR

 Barrique

LIEBHERR SINGLE ZONE WINE CELLAR WKb 1712

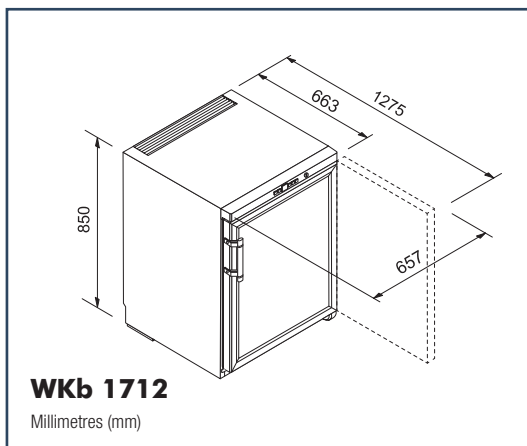

Whilst every effort is made to ensure all specifications and information in this flyer are correct at time of printing, Andi-Co Australia Pty. Ltd. reserve the right to make changes without notification. Where actual appliance measurements, specifications and ratings are crucial, we recommend that the actual appliance installation instructions that accompany each appliance be checked. Andi-Co Australia will not be liable for any loss.



Model	WKb 1712
Type Category	FS Barrique
Finish	Black
°Energy consumption (kWh/yr) 24hr	°149 0.408
△Bottle capacity (750ml Bordeaux)	60
Safety glass door	•
MagicEye control system Display	• LED
Digital temperature display	External
Tinted glazed door	Double
Temperature zones	1
Temperature range (°C) Min Max °C	5 20
Suitable for ambient temperature Min Max °C	10 38
Interior light	Vertical LED
Beech wood shelves	2
Base shelves	1
Recirculated air cooling	•
Fresh air supply via activated charcoal filter	•
Child proof lock (control panel)	•
Ergonomic SlimLine handles	•
Reversible door hinges	•
Key lock	•
Label holders	•
Compressors	1
Door open warning signal	•
Temperature alarm	•

Technical Information

Default hinge	Right
Gross weight (kg) Net weight (kg)	50 45
Height (mm)	850
Width (mm)	657
Depth (mm)	663
Voltage (V) Rated Current (A)	220-240 0.6
Made in	Malaysia

KEY: FS = Freestanding, ° = Measurements taken at +25°C ambient and +12°C interior temperature tested by Liebherr Germany (not to Australian standards), △ = Based on Bordeaux 750ml bottle - capacity may vary depending on bottle shape and size. Door hinging either right or left hand must be nominated for this model.

If building into cavity, please note the below requirements:
 Minimum air space above cabinet (mm): 50mm
 Minimum air space behind cabinet (mm): 50mm
 Minimum air space on sides of cabinet (mm): 15mm