

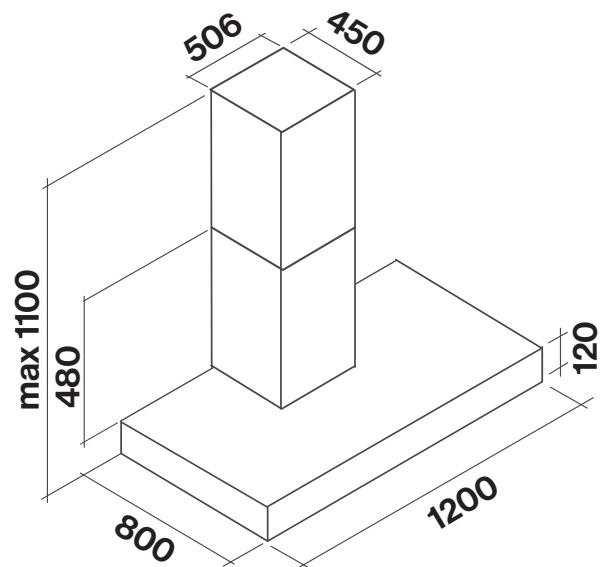

Product Features

Motor Type	Off Board Motor
Dimensions	1200 x 800 x 1100mm Suits 90cm-130cm cooking surfaces
Filtration Type	Baffle Filters x 6
Lighting	LED Strip Light 24 W (5500 K)
Finish	AISI304 Scotch Brite Stainless
Controls	Touch Control (Remote Control Optional)
Speed Settings	3 Speed + Boost
Timer Function	15 Min Auto Shut-Off
Ducting	200mm Circular Outlet + 5m of flexible ducting supplied
Other	N/A

Dimensioned Drawings



Model Code	Motor Output	Installation Option
F5TN12S1-ER2010	2010 m ³ /hr	External Roof Motor
F5TN12S1-EW2010	2010 m ³ /hr	External Wall Motor