



Tumble dryer

T509HPW.AU

Style

Series 5

Capacity: 9 kg

Condenser with heat pump

Number of programmes: 18

Installation: Freestanding

Energy stars: 8

Construction and performance

- Inner drum: Stainless Steel
- Motor: Long life and quiet brushless motor
- Heating system: Heat pump
- Drying types: Sensor or time controlled
- Drum size: 117 l
- Shortest program time: 30 min
- Easy to use lint filter: Yes, Asko double lint filter

Use and flexibility

- Water tank volume: 6.5 l
- Automatic programs: Yes
- Door opening diameter: 340 mm
- Door maximum opening angle: 180 °
- Sensors: Moisture sensor
- Auto condenser filter cleaning: No
- Load Light™ - Illumination of the drum: Yes

Interaction and control

- Remaining time indication: Yes
- Type of display: TFT - Full colour touch display (possible to interact with jog dial as well)
- Indication when program is ready: Yes
- Language settings: Chinese simplified, Chinese traditional, Swedish, Slovenian, Slovak, Russian, Polish, Norwegian, Dutch, Latvian, Lithuanian, Japanese, Italian, Croatian, French, Finnish, Estonian, Spanish, English, German, Danish, Czech

Programs and options

- Number of programmes: 18
- Drying programs: Auto normal dry, Wool, Time program, Bedding, Drum cleaning, Antiallergy, Jeans, Quick pro cotton, Down/bulky items, Mixed laundry, Synthetics, Sensitive, Cotton iron, Cotton storage, AirRefresh, Conditioning, SportWash, Shirts
- Settings: Half load, Load level setting, Delayed start, Setting of dryness level, Timed drying, Anti-crease function, Low temperature option, Disinfection mode, Pause, Beep indicating that program is ended, Quick dry

Design and integration

- Door hinge placement: Right/Left
- Adjustable feet: 15 mm
- Easy mounting of ASKO dryer on top of the washers: Yes
- Loading type: Front load

Safety and maintenance

- Child lock on display: Yes
- Overheat protection: For motor and electronics

Technical data

- Noise level drying dB(A): 59
- Energy stars: 8
- Power consumption in standby mode: 0.39 W

- Consumption in off mode: 0.22 W
- Plug type: AU plug
- Connected load: 700 W
- Voltage (V): 220-240 V
- Number of phases: 1
- Fuse: 10 A
- Frequency: 50 Hz
- Net weight: 54.9 kg
- ISO 14001 certified manufacturing: Yes

Dimensions

- Width: 595 mm
- Height: 850 mm
- Depth: 630 mm
- Depth with door open: 1080 mm
- Length of electrical cord: 2100 mm

Logistic information

- Packaging width: 636 mm
- Packaging height: 920 mm
- Packaging depth: 743 mm
- Gross weight: 59.4 kg
- Product code: 746424
- EAN code: 3838783003263

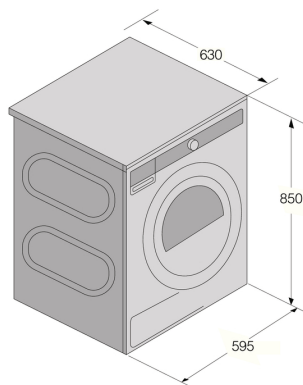

TD76/S&H/heat pump

