

INTEGRATED APPLIANCES

SUIK 1550



LIEBHERR

LIEBHERR COMPACT UNDERBENCH REFRIGERATOR SUIK_o 1550



Soft System

Model	SUIK _o 1550
Type	UB - FI
Finish	Own cabinetry
Energy consumption (kWh/yr) Star rating	158kWh 3.5
Compressors	1
Total capacity litres (L) - Gross Net	136 124
Refrigerator gross (L) net (L)	136 124
MagicEye control system Display	• LCD
Child proof setting for display & temp.	•
LED standard lighting	•

Refrigerator Features

Fruit & vegetable bin storage space	1
SuperCool	•
GlassLine shelves	•
Egg tray	•
Automatic refrigerator defrosting	•

Technical Information

Door	Pull-out trolley
Voltage (V) Rated Current (A)	220-240 1.2
Made in	Germany

KEY: UB = Underbench, FI = Fully Integrated.
Door hinging either right or left hand must be nominated for this model.

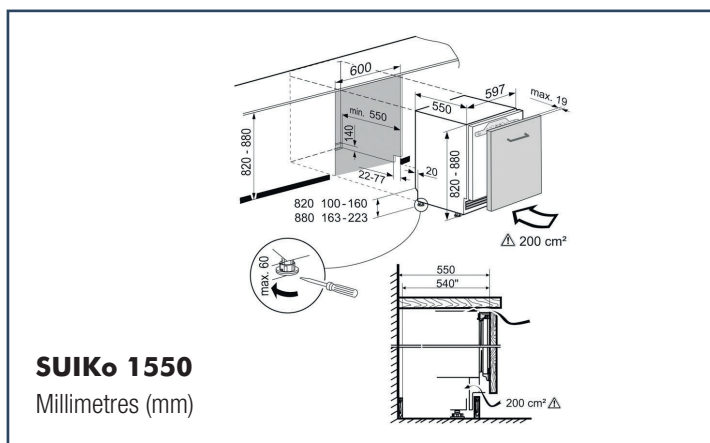

Whilst every effort is made to ensure all specifications and information in this flyer are correct at time of printing, Andi-Co Australia Pty. Ltd. reserve the right to make changes without notification. Where actual appliance measurements, specifications and ratings are crucial, we recommend that the actual appliance installation instructions that accompany each appliance be checked. Andi-Co Australia will not be liable for any loss.

Anticipated arrival early 2019