

INTEGRATED APPLIANCES

SUIK 1510



LIEBHERR

LIEBHERR COMPACT UNDERBENCH REFRIGERATOR SUIK 1510

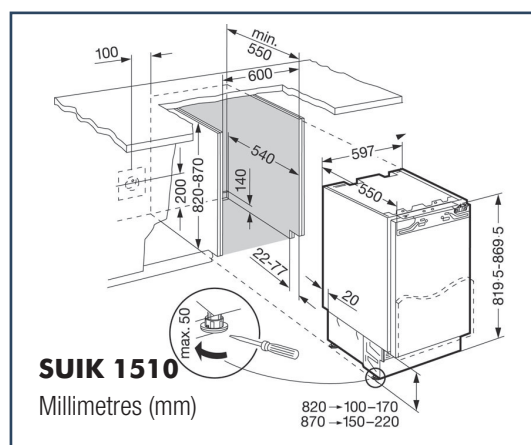

Soft System

3 Year Warranty

Model	SUIK 1510
Type	UB - FI
Finish	Own cabinetry
Energy consumption (kWh/yr) Star rating	147kWh 3.5
Compressors	1
Total capacity litres (L) - Gross Net	141 135
Refrigerator gross (L) net (L)	141 135
MagicEye control system Display	• LCD
Child proof setting for display & temp.	•
LED standard lighting	•
SoftSystem hinge - assists closure	•
115° door opening	•

Refrigerator Features

Fruit & vegetable crisper bin	1
SuperCool	•
GlassLine shelves	•
Elegant holding columns	•
Bottle shelf Egg tray	• •
Automatic refrigerator defrosting	•

Technical Information

Default hinge	Right
Voltage (V) Rated Current (A)	220-240 1.2
Made in	Germany

KEY: UB = Underbench, FI = Fully Integrated.
Door hinging either right or left hand must be nominated for this model.

Whilst every effort is made to ensure all specifications and information in this flyer are correct at time of printing, Andi-Co Australia Pty. Ltd. reserve the right to make changes without notification. Where actual appliance measurements, specifications and ratings are crucial, we recommend that the actual appliance installation instructions that accompany each appliance be checked. Andi-Co Australia will not be liable for any loss.