

INTEGRATED APPLIANCES

SUIG 1514



LIEBHERR

LIEBHERR COMPACT UNDERBENCH FREEZER SUIG 1514

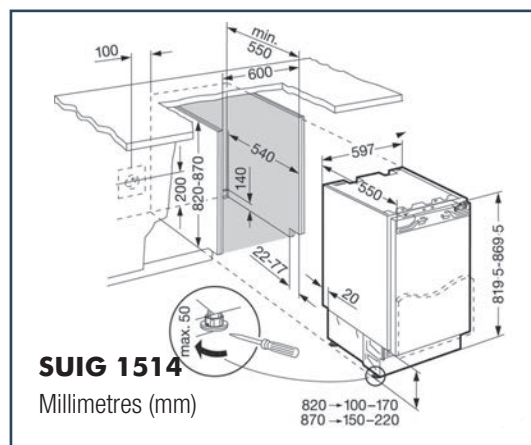

Whilst every effort is made to ensure all specifications and information in this flyer are correct at time of printing, Andi-Co Australia Pty. Ltd. reserve the right to make changes without notification. Where actual appliance measurements, specifications and ratings are crucial, we recommend that the actual appliance installation instructions that accompany each appliance be checked. Andi-Co Australia will not be liable for any loss.



Smart Frost

Soft System

3 Year Warranty

Model	SUIG 1514
Type	UB-FI
Finish	Own cabinetry
Energy consumption (kWh/yr) Star rating	168kWh 3.5
Compressors	1
Total capacity litres (L) - Gross Net	98 95
Freezer gross (L) net (L)	98 95
MagicEye control system Display	• LCD
Child proof setting for display & temp.	•
SoftSystem hinge - assists closure	•
115° door opening	•
Temperature alarm	•
Malfunction warning signal	•

Freezer Features

Cooling System	SmartFrost
Freezer Defrosting	Manual
Transparent Freezer Drawers	3
SuperFrost	•
VarioSpace	•
24hr freezing capacity (kg)	12
Cold storage accumulators	2

Technical Information

Default hinge	Right
Voltage (V) Rated Current (A)	220-240 1.3
Made in	Germany

KEY: UB = Underbench, FI = Fully Integrated.
Door hinging either right or left hand must be nominated for this model.

