



Product Features

<b>Motor Type</b>	Remote (Inline or Wall Mounting)
<b>Filtration Type</b>	Metallic Grease Filter Perimeter Suction
<b>Controls</b>	Electronic Control (Remote Control Included)
<b>Speed Settings</b>	3 Speed + Boost
<b>Timer Function</b>	15 Min Auto Shut-Off
<b>Ducting</b>	200mm Circular Outlet + 5m of flexible ducting supplied
<b>Included Accessories</b>	90° Elbow Wall Vent (Inline Motor Only)
<b>Other</b>	N/A

\* Maximum distance from cooktop 150cm

Dimensioned Drawings

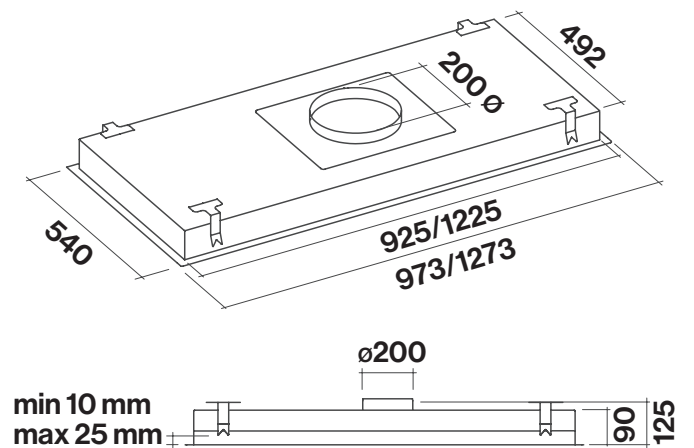

Model Code	Hood Mounting	Size	Motor Output	Lighting	Finish
F9ST90S1-IN1300 •	Ceiling	90cm	1300 m <sup>3</sup> /hr	LED 4 x 3.6 W (4000K)	Stainless Steel
F9ST90S1-EW1500 •	Ceiling	90cm	1500 m <sup>3</sup> /hr	LED 4 x 3.6 W (4000K)	Stainless Steel
F9ST90W1-IN1300 •	Ceiling	90cm	1300 m <sup>3</sup> /hr	LED 4 x 3.6 W (4000K)	White
F9ST90W1-EW1500 •	Ceiling	90cm	1500 m <sup>3</sup> /hr	LED 4 x 3.6 W (4000K)	White
F9ST12S1-IN1300 •	Ceiling	120cm	1300 m <sup>3</sup> /hr	LED 4 x 3.6 W (4000K)	Stainless Steel
F9ST12S1-EW1500 •	Ceiling	120cm	1500 m <sup>3</sup> /hr	LED 4 x 3.6 W (4000K)	Stainless Steel

Special Order •