

SOA6104S4PG

60CM LINEA STEAM100 PRO OVEN

MADE IN ITALY

Since 1948



FULL SIZE STEAM COOKING

Discover the Steam100 Pro, a full size oven that combines traditional and steam cooking to create tasty and nutritious dishes. Maximum flexibility in steam selections with manual pulse, injected or continuous steam technology delivers fresh flavours, healthy foods and beautifully browned yet juicy dishes. Combine steam with traditional cooking for up to 13 hours at a 20% steam level or over 2 hours at full 100% steam cooking.



TEN TRADITIONAL COOKING FUNCTIONS:

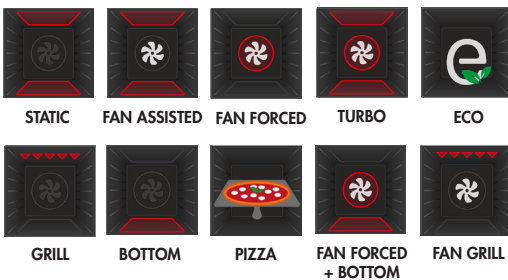

FIVE STEAM ASSISTED COOKING FUNCTIONS:



SIX CONTINUOUS STEAM COOKING FUNCTIONS:

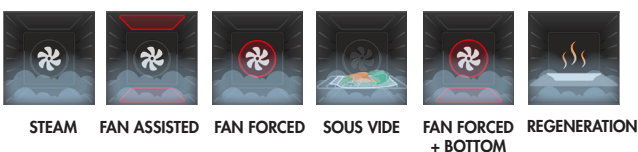

OTHER FUNCTIONS:

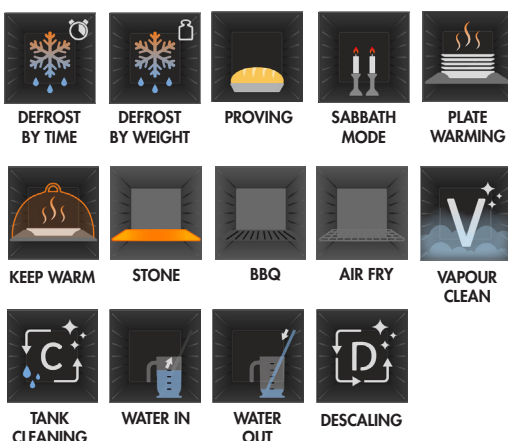

FILL & HIDE WATER LOADING

Refill the extra large 2L water tank of the Steam100 Pro without opening the oven door and disrupting the cooking cycle. The Fill & Hide system also saves time as it calculates and loads the right amount of water needed for cooking.

SMART COOKING

Let the oven do the work for you and cook with 150 built-in auto programmes. Plus, you can even save the oven settings of up to 10 of your favourite recipes so they can be simply called up at the touch of a button.

MULTI-STEP PROGRAMMING

Pre-set two different steps before you start cooking to allow for utmost versatility to achieve the perfect finish. It's no fuss, set and forget cooking.

MULTI-POINT TEMPERATURE PROBE

Cook like a professional. The multi-point probe measures the internal temperature of your food at three different points for precise cooking results.

VIVOSCREEN

Intuitive, easy to read and simple to use. Full colour and high definition images illustrate the extensive range of automatic programmes for smart cooking.

NEPTUNE GREY: THE NEW NEUTRAL

An elegant aesthetic that incorporates modern minimalistic design trends with an on-trend neutral colour, Linea is characterised by symmetrical lines, balance and light. Any combination of premium Linea appliances will make a real style statement in the kitchen.

SOA6104S4PG

60CM LINEA STEAM100 PRO OVEN

MADE IN ITALY

Since 1948

OVEN FEATURES

EAN	8017709327750
Dimensions	597mmW x 592mmH x 548mmD (excludes door and handle)
Finish	Neptune Grey
Cooking functions	21
Other functions	14
Steam range	20% - 100%
Steam delivery	Injection
Display	VivoScreen
Gross volume	79L
Net volume	68L
Water tank capacity	2L
Shelf positions	5
Thermostat	30° C - 250° C
Smart cooking	Yes (150 automatic programmes)
Cooking with probe	Yes
DeltaT cooking	Yes
SameTime	Yes
Multi-step cooking	Yes (2 step)
Rapid pre-heat	Yes
Instant GO	Yes
Installation	Built-in
Cleaning	Vapour Clean
Lighting	2 x 40W Halogen
Safety	Thermal protection system, control lock
Timer	Delay start and automatic end cooking 2 x Minute minders
Door	Soft open and close
Power	220-240V, 50/60Hz 3000W 13A Connection
Warranty	Five years parts and labour

TEN TRADITIONAL COOKING FUNCTIONS:



FIVE STEAM ASSISTED COOKING FUNCTIONS:

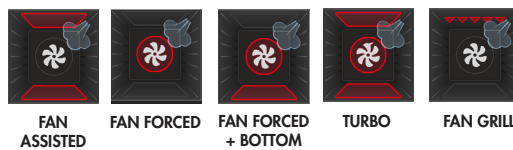

SIX CONTINUOUS STEAM COOKING FUNCTIONS:

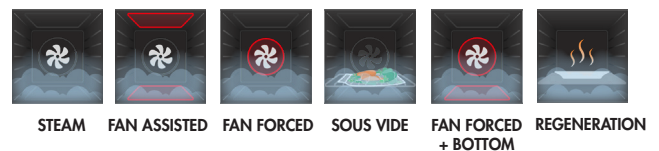

OTHER FUNCTIONS:

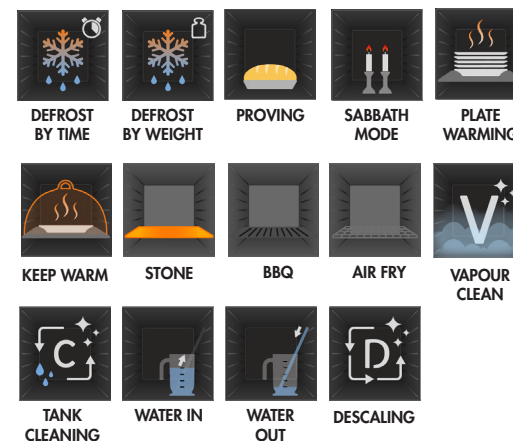

INCLUDED ACCESSORIES

- 1 x Premium chrome shelf
- 1 x Chrome grill insert
- 1 x ET50 - 50mm enamelled baking tray
- 1 x 20mm stainless steel solid full tray
- 1 x BX640PL - 40mm stainless steel perforated full tray
- 1 x Multi-point temperature probe

OPTIONAL ACCESSORIES

- BX640 - 40mm stainless steel solid half tray
- BX640P - 40mm stainless steel perforated half tray
- BX640PL - 40mm stainless steel perforated full tray
- ET20 - 20mm enamelled baking tray
- ET50 - 50mm enamelled baking tray
- GTTV2 - Full telescopic guides
- BBQ - Double sided teflon coated aluminium BBQ tray
- AIRFRY - Air fry rack
- STONE - Pizza stone

SOA6104S4PG
60CM LINEA STEAM100 PRO OVEN

MADE IN ITALY
Since 1948

MATCHES WELL WITH:



SOPA6104S2PG
60CM LINEA PYRO STEAM OVEN



SO4104APG
COMPACT LINEA OMNICHIEF OVEN



CPV115G
VACUUM DRAWER

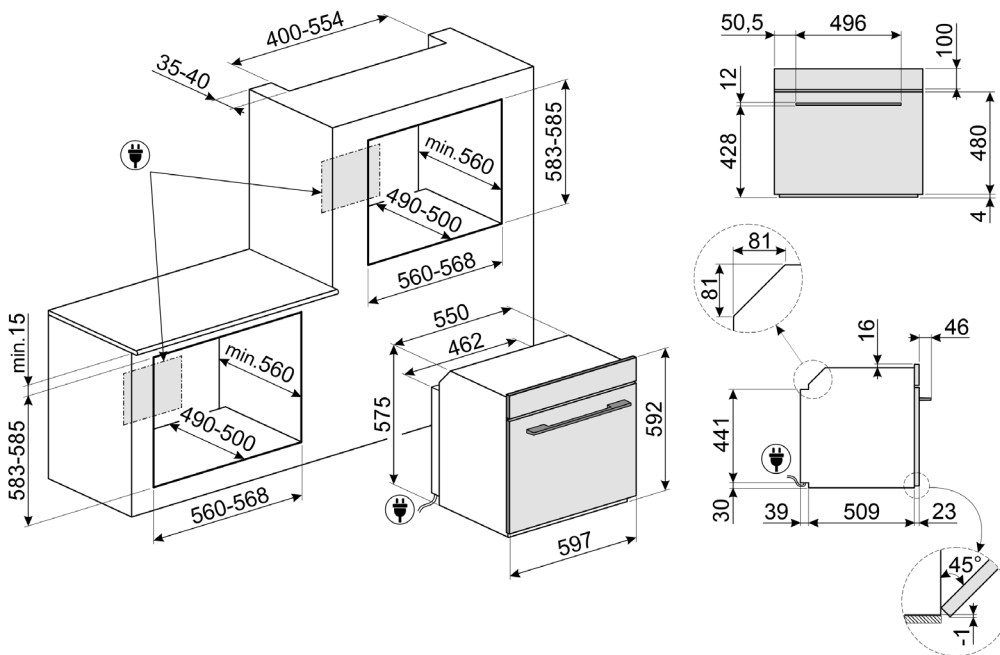

Dimensions	597mmW x 592mmH x 548mmD (excludes door and handle)
Power	220-240V, 50/60Hz 3000W 13A Connection

PLEASE NOTE: drawings are not to scale. They are to assist only.
WARNING: technical specifications and product sizes can be varied by the manufacturer without notice.
Cutouts for appliances should only be by physical product measurements. The above information is indicative only.