

# 'HALO' CEILING CASSETTE RANGEHOOD - OFFBOARD MOTOR

SLT-973 EM

valentina  
collection



Light ring colours available	White (WH), Black (BK), Gold (G), Copper (C), Silver (XS) (shown above)
------------------------------	---

Rangehood type	Ceiling cassette
Control	Remote control
Speed settings	4
Ducting diameter	Rectangular ducting
Extraction type	Offboard motor
Motor*	SEM 1, SEM 2 XS316, SEM 5 XS316
Filter	Aluminium filter
Lighting	LED Light ring
Induction Countdown Control	Yes
Electrical requirement	10A
Weight	19kg gross / 11.5kg net
Motor dimensions (mm)	W540 diameter x H200
Light dimensions (mm)	W750 x D750 x H35
Cut-out dimensions (mm)	W510 diameter
Warranty	3 years (6 years when Sirius ducting is used)

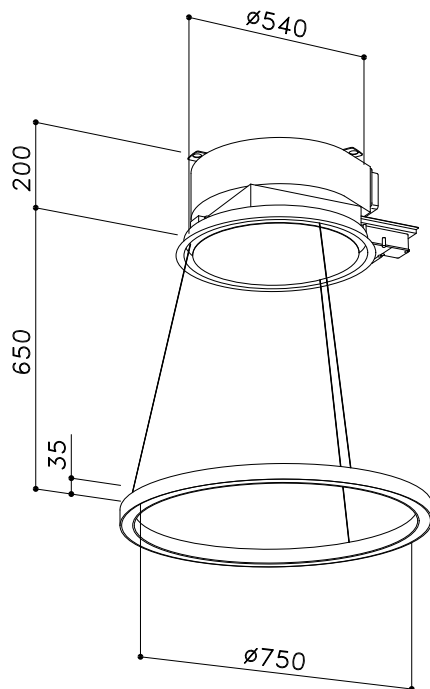
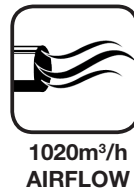
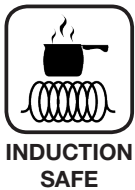

\*Outdoor offboard motors have a marine grade finish as standard for added resistance to coastal weather elements.

## Ducting options

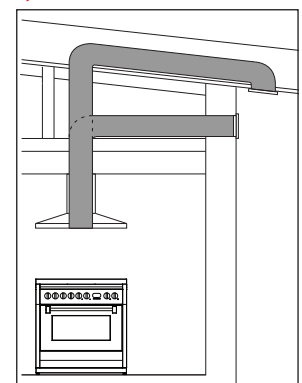
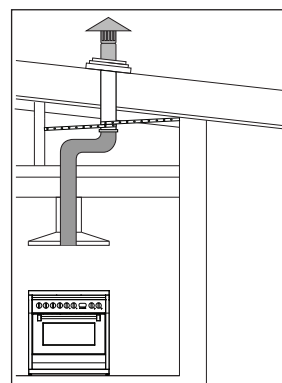

- Can be used with SEM 1, SEM 2, and SEM 10.
- Use semi-rigid or rigid ducting, not fully flexible foil ducting.
- Fewer bends means a quieter and more powerful extraction.
- Extra 3 years warranty when Sirius ducting is used (total 6 years).
- See [support page](#) on Sirius website for installation videos and FAQs.

WARNING: technical specifications and product sizes can be varied by the manufacturer, without notice. Cut outs for appliances should only be by physical product measurements. The above information is indicative only.

Distributed by Arisit Pty Ltd

40-50 Mark Anthony Drive, Dandenong South VIC 3175

Ph: 1300 762 219

Fax: 03 9768 0838

Website: [www.arisit.com](http://www.arisit.com)

[www.siriusbrand.com](http://www.siriusbrand.com)

06/2020

# 'HALO' LIGHT ONLY

SLT-973 LAMP

valentina  
collection



Dimensions (light) (mm)	W750 diameter x H35
Dimensions (mount)	W540 diameter x H115
Light ring colours available	White (WH), Black (BK), Gold (G), Copper (C), Silver (XS) (shown above)

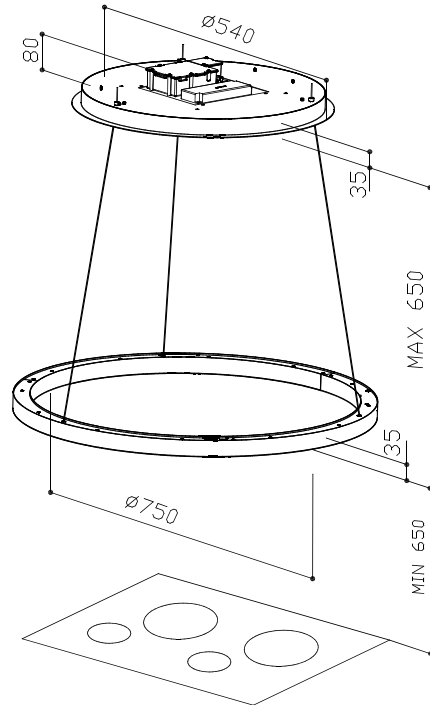

WARNING: technical specifications and product sizes can be varied by the manufacturer, without notice.  
Cut outs for appliances should only be by physical product measurements. The above information is indicative only.

Distributed by Arisit Pty Ltd

40-50 Mark Anthony Drive, Dandenong South VIC 3175

Ph: 1300 762 219

Fax: 03 9768 0838

Website: [www.arisit.com](http://www.arisit.com)

[www.siriusbrand.com](http://www.siriusbrand.com)