

# PENDANT RECIRCULATING RANGEHOOD

SILT-26

valentina  
collection



Pendant colours available	White (W), Matte Black (B), Gold (G), Grey (XS), Copper (C) (shown above)
---------------------------	---

Rangehood type	Pendant
Control	Remote control
Speed settings	4
Ducting	N/A (recirculating)
Extraction type	Filtering and recirculating
Motor	Single onboard aluminium
Filter	HP recirculating insert
Extraction	600m³/h
Noise	68 dBA
Lighting	LED Light ring
Induction Countdown Control	Yes
Electrical requirement	10A
Dimensions (motor/light) (mm)	W690 diameter x H210
Weight	26kg
Warranty	6 years



**INDUCTION SAFE**



**RECIRCULATING HOOD**



**REMOTE CONTROL**



**SPEED SETTINGS**



**SINGLE ONBOARD MOTOR**



**600m³/h AIRFLOW**



**LED LIGHT RING**



**HANDCRAFTED IN ITALY**

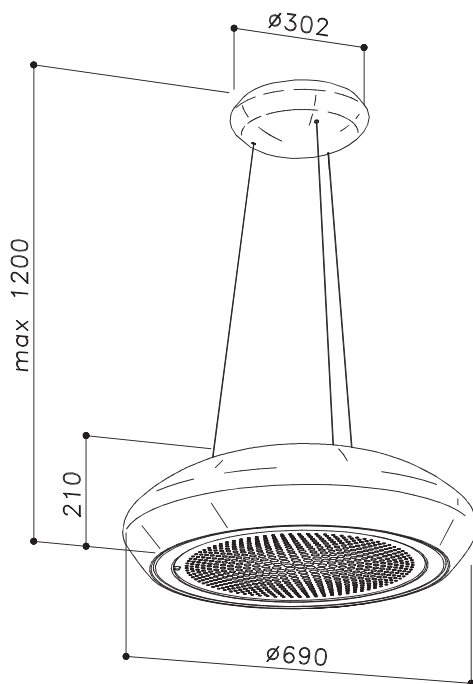

## PENDANT LIGHT ONLY

SILT-26 LAMP



Dimensions (motor/light) (mm)	W690 diameter x H210
Pendant colours available	White (W), Matte Black (B), Gold (G), Grey (XS), Copper (C) (shown above)

WARNING: technical specifications and product sizes can be varied by the manufacturer, without notice. Cut outs for appliances should only be by physical product measurements. The above information is indicative only.

Distributed by Arisit Pty Ltd

40-50 Mark Anthony Drive, Dandenong South VIC 3175

Ph: 1300 762 219

Fax: 03 9768 0838

Website: www.arisit.com

[www.siriusbrand.com](http://www.siriusbrand.com)

06/2020