

## SFPA9305SPX 90CM CLASSIC THERMOSEAL OVEN



EAN 8017709290917

Dimensions	896mmW x 595mmH x 571mmD
Finish	Fingerprint proof stainless steel Eclipse high visibility black glass
Total functions	15 plus Defrost, Proving, Sabbath, & Pyrolytic 53 Automatic programmes
Display	VIVOScreen Max
Capacity	129L
Cooking levels	5
Thermostat	30 - 280°C
Installation	Built-in
Programmability	Fully programmable
Cleaning	Pyrolytic cleaning
Lighting	2 x 40W halogen
Supplied accessories	1 x Chrome shelves 1 x Chrome grill insert 2 x 40mm enamelled baking tray 1 x GT1T2 - Total telescopic guides 1 x Temperature probe
Optional accessories	PRTX - Pizza Stone GT1P-2 - Partial telescopic guides
Safety	Cool Door technology, thermal protection system, control lock and child safety lock
Power	220-240V, 50/60Hz 4000W 18A Connection
Warranty	Two years parts and labour

### MULTI-STEP COOKING

When meals require a variety of different cooking styles, simply set Smeg's multi-step cooking function for perfect results. Whether you need to steam a beautiful piece of fish and bake or grill for the perfect finish, Smeg delivers versatility in the kitchen. Choose cooking technology, cooking function, temperature and time to stage up to 3 steps in one cooking cycle. Smeg makes challenging recipes simple to master and achieve professional results.



### VIVOSCREEN MAX

Smeg presents a brand new full colour, touch control VIVOScreen MAX which is 6.3" wide allowing more information and functions to be shown. Intuitive, easy to read and simple to use, high definition images illustrate the extensive range of automatic programs available for smart cooking. Helpful pop up explanations appear once an item on the display is held down for 3 seconds.

### TEMPERATURE PROBE

No two cuts of meat or poultry are alike. So when guests arrive, ensure a juicy and tender roast is on the dinner table everytime with this precision cooking tool.



### SMART COOKING

Smeg's intuitive Smart Cooking program allows users to effortlessly select oven functions, temperature and cooking time. Smart cooking offers 100 automatic recipes for simple operation. Select the dish you want to cook from the menu, enter the weight and the oven does the rest - resulting in perfectly cooked meals every time. The My recipes feature also allows you to store up to 64 of your favourite dishes into the memory of the oven. The cooking function, temperature, time and your own name for the dish will be saved, making the oven quick and simple to use for everyone.

SFPA9305SPX  
90CM CLASSIC THERMOSEAL OVEN

FUNCTIONS

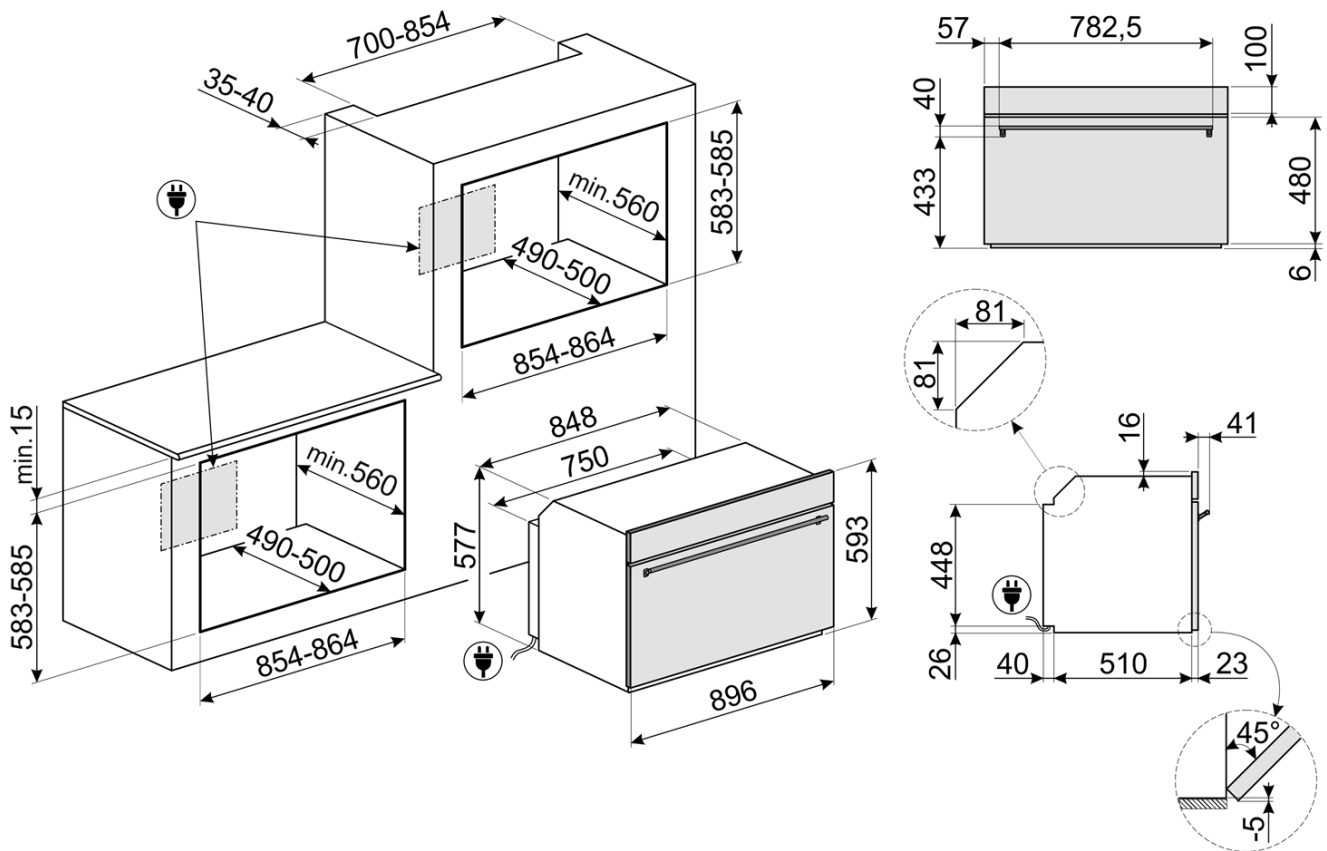
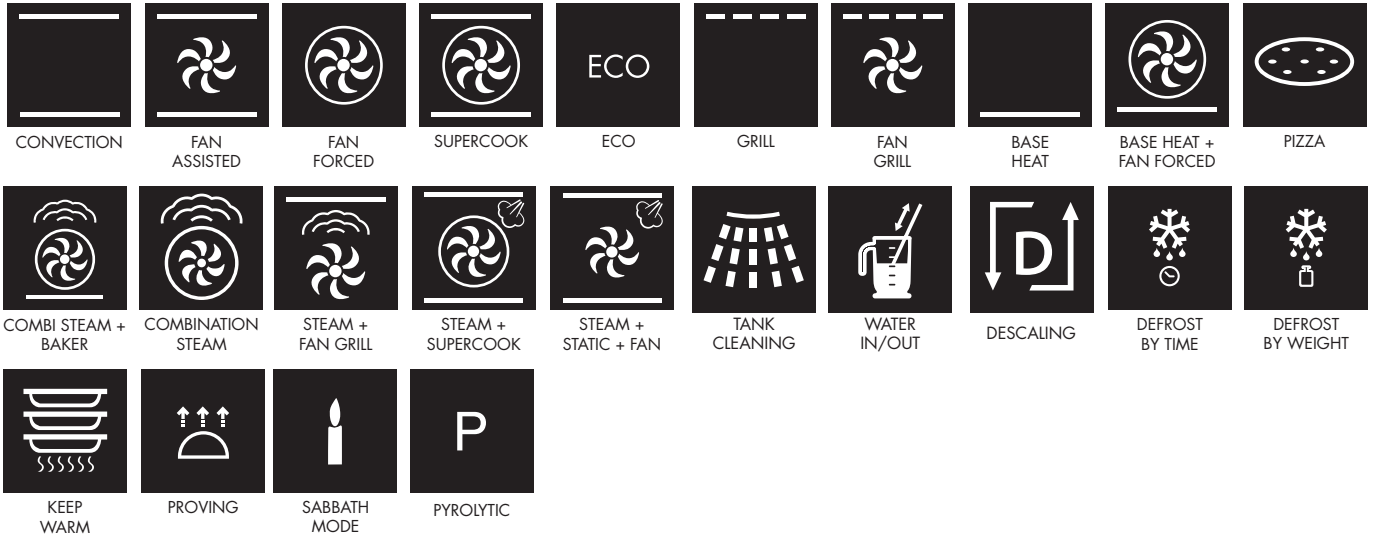

PLEASE NOTE: drawings are not to scale. They are to assist only.  
WARNING: technical specifications and product sizes can be varied by the manufacturer without notice.  
Cutouts for appliances should only be by physical product measurements. The above information is indicative only.