

1180mm INTEGRATED DOWNDRAFT RANGEHOOD

SDD2LEMIC1180

valentina
collection



Rangehood type	Integrated Downdraft
Control	Separate remote location with touch control
Speed settings	4
Ducting diameter	200mm
Extraction type	Offboard motor
Motor*	SEM7XS316, SEM71, SEM8, SEM81
Filter	Aluminium mesh filter
Safety features	Auto-stop
Lighting	Light strip
Induction Countdown Control	Yes
Electrical requirement	10A
Dimensions (fully extended) (mm)	W1133 x D97 x H300
Warranty	3 years (6 years when Sirius ducting is used)

Effective Aug 2021



**INDUCTION
SAFE**

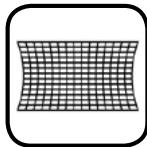

**ALUMINIUM
MESH FILTER**



**SPEED
SETTINGS**



LIGHT STRIP



**EUROPEAN-
MADE MOTOR**



**HANDCRAFTED
IN ITALY**

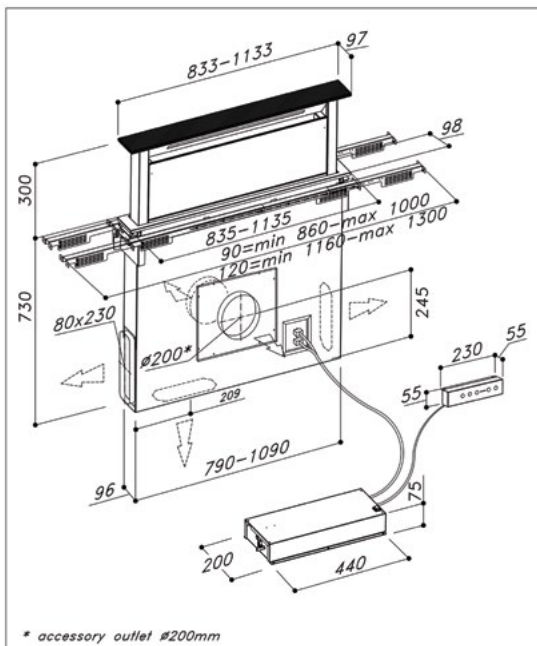

*Outdoor offboard motors have a marine grade finish as standard for added resistance to coastal weather elements.

Ducting options

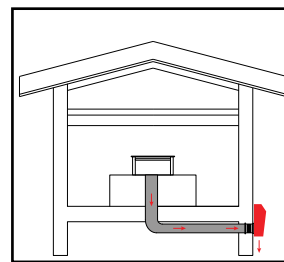

External venting
(SEM7 shown)

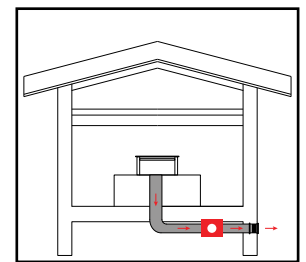

External venting
(SEM8 shown)

- Can be used with SEM7 / SEM71 and SEM8 / SEM81.
- Use semi-rigid or rigid ducting, not fully flexible foil ducting.
- Fewer bends means a quieter and more powerful extraction.
- Extra 3 years warranty when Sirius ducting is used (total 6 years).
- See [support page](#) on Sirius website for installation videos and FAQs.

WARNING: technical specifications and product sizes can be varied by the manufacturer, without notice. Cut outs for appliances should only be by physical product measurements. The above information is indicative only.

Distributed by Arisit Pty Ltd

40-50 Mark Anthony Drive, Dandenong South VIC 3175

Ph: 1300 762 219

Fax: 03 9768 0838

Website: www.arisit.com

www.siriusbrand.com