

Freestanding Refrigerator Freezer, 79cm, 494L

Series 5 | Contemporary

White | Right Hinge

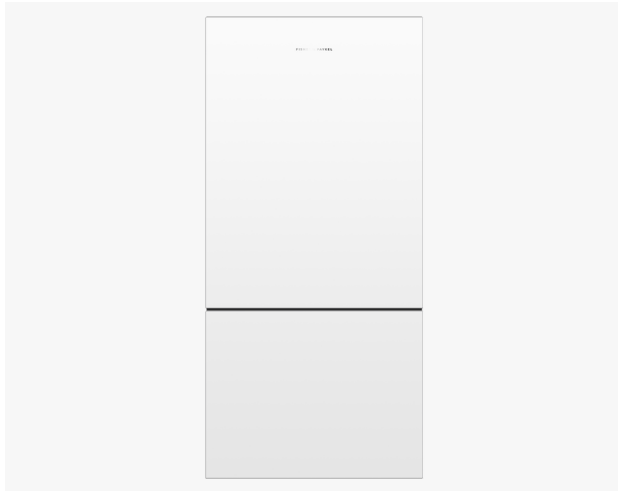

With ample storage and a stylish stainless steel finish, for a timeless look.

- ActiveSmart™ technology helps keep food fresher for longer by constantly maintaining the ideal temperature.
- Spacious bottom freezer with easy-slide internal drawers to separate storage

DIMENSIONS

Height	1720mm
Width	790mm
Depth	695mm

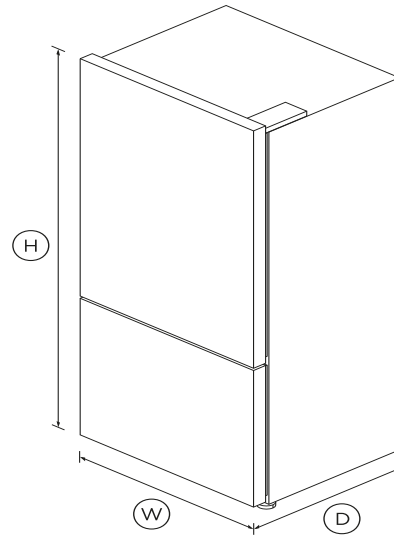

FEATURES & BENEFITS

ActiveSmart™ Foodcare

ActiveSmart™ Foodcare learns how you live. It's technology which understands how you use your refrigerator and adjusts temperature, airflow and humidity inside to help keep food fresher for longer.

Humidity control

Your fruit and veges need different environments. The humidity control slides in each storage bin create a microclimate that helps keep food fresher for longer.

Simple storage

This fridge is designed to make it simple for you to store, access and remove food. Storage bins give you full access inside when they're pulled open and can be easily removed to clean. Our flexible shelving also gives you more storage options.

Clever energy

Your refrigerator adapts to daily use by cooling and defrosting only when needed. This means it uses the energy it needs without compromising on food care.

Easy cleaning

Spill-safe secure glass shelves easily capture any drips or leaks and prevent them from falling on items below.

Design quality

Our refrigerators are designed and built using quality materials. We use pre-painted steel, and solid glass for shelving.

SPECIFICATIONS

Capacity

Volume	494L
Volume freezer	146L
Volume refrigerator	348L

Consumption

Energy rating	3 star
Energy usage	467kWh/year

Features

Adjustable door shelves	4
Adjustable glass shelves	4
Covered door shelves	2
Door alarm	•

Front levelling feet	•
Fruit and vegetable bins	2
Full extension runners	•
LED lighting	•
Rear rollers	•
SmartTouch control panel	•
Spill proof removable bins	•
Stackable bottle holders	2

Freezer Features

Bottle chill	•
Fast freeze	•
Large plastic bins	•
Slide Out Pastry Tray	•

Performance

ActiveSmart™ Foodcare	•
ActiveSmart™ technology	•
Adaptive defrost	•
Frost free	•
Frost free freezer	•
Inverter controlled compressor	•
R600a refrigerant	•

Product dimensions

Depth	695mm
Height	1720mm
Height to top of cabinet	1720mm
Width	790mm

Warranty

Parts and labour	2 years
Sealed system parts only	additional 3 years

SKU	25027
-----	-------

The product dimensions and specifications in this page apply to the specific product and model. Under our policy of continuous improvement, these dimensions and specifications may change at any time. You should therefore check with Fisher & Paykel's Customer Care Centre to ensure this page correctly describes the model currently available. ? Fisher & Paykel Appliances Ltd 2020



A PEACE OF MIND SALE

24 Hours 7 Days a Week Customer Support

T 1300 650 590 www.fisherpaykel.com