

TECHNICAL DATASHEET

NEPTUNE NEX 611 RHD

Product Category	Sinks
Finish	Stainless Steel
Installation	Inset
Range	NEPTUNE
Model	NEX 611 RHD
Warranty	50 Years



PRODUCT INFORMATION

Article Number	101.0059.633
Dimensions	860 x 510mm
Cabinet Base	600mm
Bowl Size	360 x 420 x 200mm/27L
Bowl Radius	50mm
Cut-Out Size	844 x 494mm, cr=20
Cut-Out Template	No
Waste Outlet	Semi Integrated Waste
Overflow	No
Tap Holes	Yes (cut out 35mm)
Remote Waste	No
Opposite Configuration	101.0059.085
Accessories	1 2 3 4 5

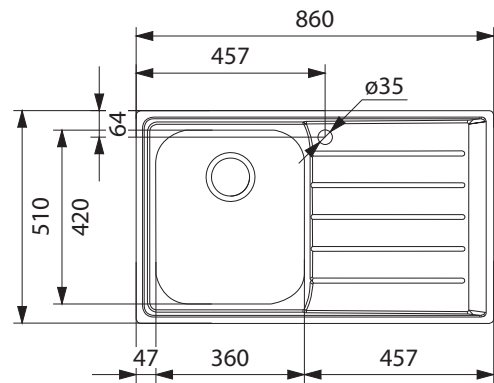

1 ACCESSORIES AVAILABLE **1** ACCESSORIES INCLUDED

ACCESSORIES

1	2	3	4	5
				
CB 601 Chopping Board	SB 603 Strainer Bowl	ST 602 Strainer Tray	DB 664 Drainer Basket	RM 44 Rollamat

FEATURES & BENEFITS

 FPC Food Preparation Centre	 18/10 Stainless Steel	 Waste to Rear of Main Bowl	 Sound Deadening Pads	 Integrated Sealing Strip
---	--	--	--	--

LAST UPDATED: 14 JAN 2016

Make it wonderful

FRANKE