

# NELIA

**BLANCO**



**Model Code**  
NELIA - Chrome

**Description**  
Single lever mixer tap

**Warranty**  
10 year warranty

## Features

## Benefits

Elegant Chrome Tap

Elegant chrome finish that greatly impresses and which will suit all types of kitchen sinks, products and worktops. It is a durable design that is easily cleaned and maintenance free.

DR Brass Body

Provides a good feeling everyday about the hygiene and health protection for the whole family, whilst using certified quality materials.

360° Swivel Spout

Allows maximum access to the sink for washing large items.

High Clearance Outlet

Gives greater ability to clean larger items in confined space.

Ceramic Disk Cartridge

Durable and long lasting ceramic disk technology.

3 Filter Removable Aerator

- Controls water flow
- Reduces splashing effect and easy to clean

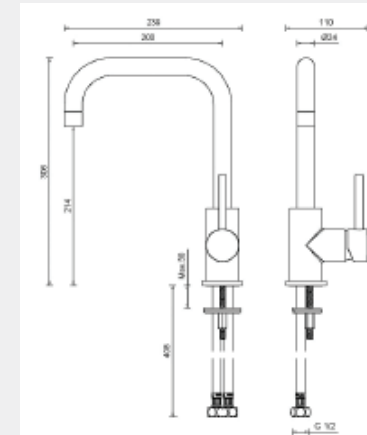

Material:	Chrome
Recommended Pressure:	300 kPa
Min Pressure:	150 kPa
Max Pressure:	1000 kPa
Dimensions:	Suitable for main or balanced water pressure 200 mm Spout length 214 mm Spout height 306 mm Tap height
Mounting Hole:	Ø35 mm Tap hole required
Standard Inclusions:	Australian standard flexible hose and fittings Stabilising plate to increase stability of the tap when fitted in stainless steel sinks
Warranty:	10 years

Note: Measurements are within 2 - 3mm of factory tolerance. It is advisable to check dimensions of physical product when measuring for installations and before doing any cut outs.

\*Due to continual product development the information provided is not final and may be subject to change.

