

## iQ700, Built-in oven with steam function, 60 x 60 cm, Black HS958GCB1

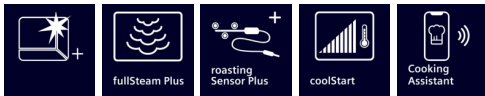

The intelligent fullSteam Plus oven with Cooking Assistant for intuitive programme setting and roastingSensor Plus for excellent results.

- ✓ Far less oven cleaning – ecoClean Plus.
- ✓ fullSteam Plus with sous-vide – For healthy and great-tasting meals.
- ✓ roastingSensor Plus – Perfect roasting results.
- ✓ fastPreheat – Heat the oven quickly. coolStart – Eliminate preheating for frozen foods.
- ✓ Cooking Assistant – Intuitively set the right programme.

### Features

#### Technical Data

Color / Material Front : Black  
 Built-in / Free-standing : Built-in  
 Door opening : Drop down  
 Cleaning : EcoClean program, Hydrolytic  
 Control Panel Material : Glass  
 Door Material : Glass  
 Dimensions (HxWxD) : 595x594x548 mm  
 Dimensions of the packed product (HxWxD) : 670x660x690 mm  
 Required niche size for installation (HxWxD) : 585-595 x 560-568 x 550 mm  
 Cavity dimensions : 355 x 480 x 415 mm  
 Usable volume of cavity : 71 l  
 Number of interior lights : 1  
 Net weight : 40.5 kg  
 Gross weight : 43.1 kg  
 EAN code : 4242003902684  
 Connection Rating : 3600 W  
 Fuse protection : 16 A  
 Voltage : 220-240 V  
 Frequency : 50; 60 Hz  
 Length electrical supply cord : 120 cm

#### Included accessories

1 x enamel baking tray, 1 x grid, 1 x universal pan, 1 x steam container, punched, size XL, 1 x sponge, 1 x steam container, punched, size M, 1 x steam container, unpunched, size M

#### Optional accessories

HZ6BMA00 Assembly kit for vertical installation  
 HZ638D00 Full ext rails, level independent, steam  
 HZ631070 Baking tray, anthracite enamelled  
 HZ629070 Air Fry & Grill tray



## iQ700, Built-in oven with steam function, 60 x 60 cm, Black HS958GCB1

### Features

#### Heating Functions

- Combi-steam oven with 24 heating methods: 4D hotAir, Top/bottom heating, Hot air grilling, Full width grill, Half width grill, Pizza setting, coolStart (deep-frozen food special), Bottom heating, Intensive heat, Low temperature cooking, Plate warming setting, Keep Warm, hotAir gentle, Conventional heat gentle, Air fry, FullSteam, Reheating, Dough Proving, Defrost, sous-vide cooking, hotair grilling + steam, keep warm + steam, 4D hotAir + steam, Top/bottom heat + steam
- Temperature range 30 °C - 250 °C.

#### Racks and Rails

- Number of shelf levels: 5
- varioClip rails Plus, full extension, with Stop function

#### Design

- studioLine Black Steel Design
- studioLine Glass handle
- TFT-Touchdisplay Pro
- Touch control
- Cavity inner surface: enamel
- Cavity volume: 71 net usable litres

#### Cleaning

- ecoClean: coating of ceiling, back panel, side liners
- humidClean Plus program - easy cleaning of a lightly soiled cooking cavity

#### Convenience

- Temperature proposal, Residual heat indicator, Actual temperature display, Meat probe function
- There are different steam intensities selectable: steam level high, steam level middle, steam level low
- steamBoost - add for 3min intensive steam with a touch of a button.
- roastingSensor Plus multipoint meat probe
- cookControl Pro
- HomeConnect
- Cooking Assistant
- coolStart - eliminates preheating for frozen foods
- Automatic rapid heat up
- Oven door with SoftOpen and SoftClose door
- Integrated cooling fan
- LED light
- Electronic clock and timer
- Water tank empty indicator
- Location of the steam generator is outside of the cavity

#### Accessories

- 1 x enamel baking tray, 1 x steam container, punched, size M, 1 x steam container, punched, size XL, 1 x steam container, unpunched, size M, 1 x grid, 1 x sponge, 1 x universal pan

#### Safety Features

- Child lock, Automatic safety switch-off function, Residual heat indicator, Start button, Door contact switch
- Triple glazed door with heat reflective glass
- Full glass inner door

#### Technical Information

- Length of mains cable: 120 cm
- Nominal voltage: 220 - 240 V
- Total connected load electric: 3.6 KW

#### Dimensions

- Appliance dimensions (HxWxD): 595 mm x 594 mm x 548 mm
- Installation dimensions (HxWxD): 585 mm - 595 mm x 560 mm - 568 mm x 550 mm
- Please reference the built-in dimensions provided in the installation drawing
- Energy efficiency rating (acc. EU Nr. 65/2014): A+(at a range of energy efficiency classes from A+++ to D)
- Energy consumption per cycle in conventional mode: 0.87 kWh
- Energy consumption per cycle in fan-forced convection mode: 0.69 kWh
- Number of cavities: 1
- Heat source: electrical
- Cavity volume: 71 net usable litres
-

## iQ700, Built-in oven with steam function, 60 x 60 cm, Black HS958GCB1

### Dimensioned drawings

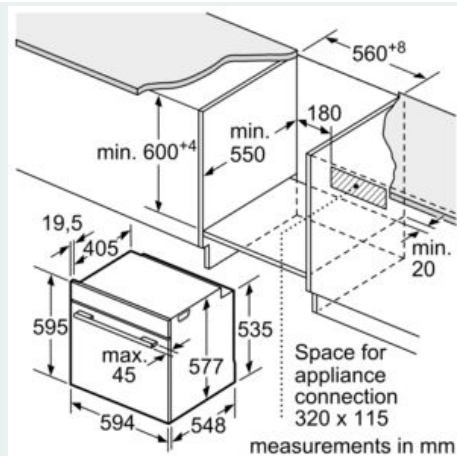
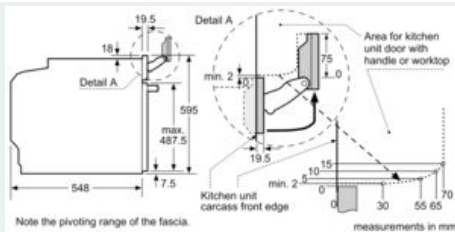

If the appliance will be installed underneath a hob, the following worktop thicknesses (including substructure if necessary) must be taken into account.

Hob type	min. worktop thickness	
	fitted	flush
Induction hob	37 mm	38 mm
Full surface Induction hob	47 mm	48 mm
Gas hob	30 mm	38 mm
Electric hob	27 mm	30 mm

Installing two appliances on top of each other  
Air exchange

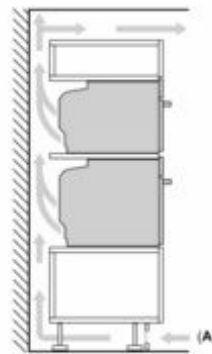

A: Air inlet  $\geq 200 \text{ cm}^2$

