

# Integrated Insert Rangehood, 60cm

Series 9 | Integrated

Stainless Steel

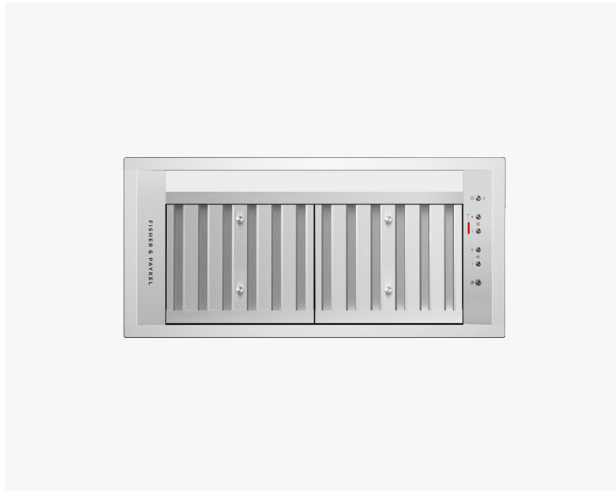

With edge-to-edge extraction, this efficient, stylish rangehood is perfectly hidden away in your cabinetry.

- With five fan speeds, select the perfect extraction rate for your cooking
- With dimmable LED strip lighting
- 700m<sup>3</sup>/hr maximum airflow
- Dishwasher safe filters that are easy to remove and clean

## DIMENSIONS

Height	407mm
Width	580mm
Depth	280mm

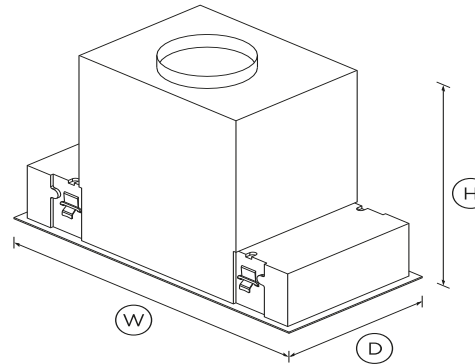

## FEATURES & BENEFITS

### EDGE TO EDGE EXTRACTION

Filters effectively reach edge to edge, which maximises the extraction area.

### FULL SURFACE LIGHTING

The even lighting provides full coverage of the cooktop, illuminating food in its true colour, with no hot or dark spots and no glare or shadows. The dimmable lights have fade in and fade out features.

### EASY TO USE

This easy to use rangehood operates with fingertip control of LED-illuminated soft touch buttons. Selected models also come

with a remote control.

### ENERGY EFFICIENCY

Powered by a brushless DC motor, the Integrated Rangehood operates more efficiently, more reliably and with less noise than units with AC motors.

### EFFORTLESS CLEANING

The stainless steel filters are easy to remove and are dishwasher safe. A self-contained grease tray within the filters makes them very easy to clean.

### SIMPLE INSTALLATION

The simple installation process is compatible with most precut cabinetry. The adjustable mounting system can be installed with 16mm to 38mm cabinetry board.

## SPECIFICATIONS

### Accessories

Remote control	50137 HPBRF1*
----------------	---------------

### Fan ratings

Maximum air movement	700m <sup>3</sup> /hr
Speed 3 sound rating	54dBA

### Installation and cleaning

Dishwasher safe filters	2
Ducted	Vertical only

### Performance

Extraction type	Surface
Fan speeds	5
Filter type	Stainless Steel Baffle

---

**Power requirements**Supply voltage **230V**

---

**Product dimensions**Depth **280mm**Height **407mm**Width **580mm**

---

**Product information**Control type **Electronic**

---

**Ventilation features**

Auto-off/Run-on timer •

Dimmable lights •

Filter cleaning alert •

Light type **LED strip**Number of light settings **5**Over heat sensing •

---

**Warranty**Parts and labour **2 years**

---

SKU **50138**

---

---

**Other product downloads available at fisherpaykel.com**

- [↓](#) Service & Warranty
- [↓](#) User Guide Integrated Rangehood
- [↓](#) Installation Guide
- [↓](#) Data Sheet Insert Rangehood

**A PEACE OF MIND SALE****24 Hours 7 Days a Week Customer Support****T 1300 650 590 W [www.fisherpaykel.com](http://www.fisherpaykel.com)**

The product dimensions and specifications in this page apply to the specific product and model. Under our policy of continuous improvement, these dimensions and specifications may change at any time. You should therefore check with Fisher & Paykel's Customer Care Centre to ensure this page correctly describes the model currently available. ? Fisher & Paykel Appliances Ltd 2020