

# Integrated Rangehood, 90cm with External Motor

Series 7 | Integrated

Stainless Steel and Glass



This integrated insert rangehood has an externally installed inline motor to deliver near silent yet powerful extraction of steam, grease and cooking odours.

- With three fan speeds plus a boost function, select the perfect extraction rate for your cooking
- External motor delivers near silent operation in the kitchen
- Powerful maximum air movement of 1200m<sup>3</sup>/hr
- Wi-Fi enabled for notifications through the SmartHQ™ app

## DIMENSIONS

<b>Height</b>	<b>315mm</b>
<b>Width</b>	<b>830mm</b>
<b>Depth</b>	<b>280mm</b>

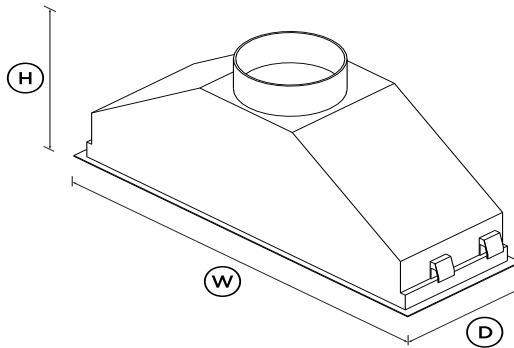

## FEATURES & BENEFITS

### NEAR SILENT EXTRACTION

The powerful external motor is installed outside the home to deliver near silent extraction of cooking odours and steam from the kitchen.

### SEAMLESS INTEGRATION

This rangehood can be built into your cabinetry for a seamless look. A black glass control panel and stainless steel finish are designed to match the rest of Fisher & Paykel's kitchen appliance family.

### EFFECTIVE EXTRACTION

This rangehood features three fan speeds plus boost function, providing powerful extraction to quickly remove odours and steam. As odours can linger in the kitchen well after cooking is finished, the timer keeps the rangehood working for up to 15 minutes before automatically turning off.

### FULL SURFACE LIGHTING

Energy-efficient, dimmable LED lights provide superb illumination over the entire cooking surface.

### EASY CLEANING

Designed for simple removal, the filters are easy to clean and dishwasher safe, while the glass and stainless steel finish is easily wiped clean. The SmartHQ™ app will notify you when to clean the filters to ensure you get the best performance out of your rangehood.

### CONSIDERED EFFICIENCY

The right amount of air is extracted to effectively remove cooking odours with reduced effect on your heating or air conditioning.

## SPECIFICATIONS

### Accessories (included)

Aluminium filter	<b>792943</b>
External motor kit	<b>50170 HB 1200E* (included)</b>
Extra ducting length	<b>792961</b>
Light bulb	<b>requires service to replace</b>

### Fan ratings

Maximum air movement	<b>1200m<sup>3</sup>/hr</b>
----------------------	-----------------------------

### Installation and cleaning

Dishwasher safe filters	<b>2</b>
-------------------------	----------

Ducted	Top extraction
--------	----------------

SKU	50192
-----	-------

**Performance**

Extraction type	Perimeter
Fan speeds	4
Filter type	Mesh with perimeter
Number of filters	2

The product dimensions and specifications in this page apply to the specific product and model. Under our policy of continuous improvement, these dimensions and specifications may change at any time. You should therefore check with Fisher & Paykel's Customer Care Centre to ensure this page correctly describes the model currently available. ? Fisher & Paykel Appliances Ltd 2020

**Power requirements**

Supply frequency	50Hz
Supply voltage	240V

**Product dimensions**

Depth	280mm
Height	315mm
Width	830mm

**Product information**

Control type	Capacitive touch
--------------	------------------

**Ventilation features**

Auto-off/Run-on timer	•
Dimmable lights	•
Filter cleaning alert	•
Light type	LED strip
Timer function	•

**Warranty**

Parts and labour	2 years
------------------	---------

**Other product downloads available at fisherpaykel.com**[Service & Warranty](#)[Preliminary Specification Guide Rangehood](#)**A PEACE OF MIND SALE****24 Hours 7 Days a Week Customer Support****T 1300 650 590 W [www.fisherpaykel.com](http://www.fisherpaykel.com)**