

# Integrated Insert Rangehood, 60cm

Series 7 | Integrated

Stainless Steel and Glass



With edge-to-edge extraction, this rangehood is perfectly hidden away in your cabinetry.

- With three fan speeds plus a boost function, select the perfect extraction rate for your cooking
- Powerful maximum air movement of 780m<sup>3</sup>/hr
- Energy-efficient LED lighting to illuminate your cooking surface
- Wi-Fi enabled for notifications through the SmartHQ™ app

## DIMENSIONS

Height	595 - 1035mm
Width	598mm
Depth	500mm

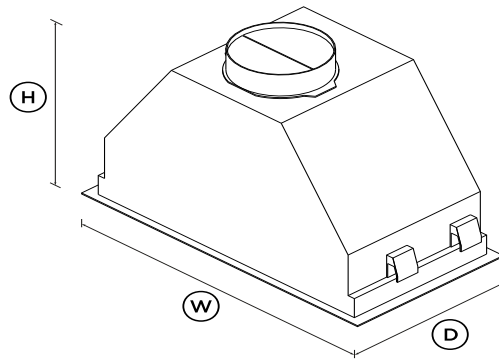

## FEATURES & BENEFITS

### ACHIEVE THE INVISIBLE

This stylish rangehood fits seamlessly into your kitchen cabinetry, providing ventilation that is as discreet as it is powerful.

### EFFECTIVE EXTRACTION

Featuring three fan speeds, plus a boost function, this rangehood provides powerful extraction to quickly remove odours and steam. Odours can linger in the kitchen well after cooking is finished so the timer keeps the hood working for up to 15 minutes before automatically turning off.

### EASY CLEANING

Designed for simple removal, the filters are easy to clean and dishwasher safe, while the glass and stainless steel finish is easily wiped clean. The SmartHQ™ app will notify you when to clean the filter to ensure you get the best performance out of your rangehood.

### QUALITY MATERIALS

This rangehood comes in a sleek black glass finish with a real stainless steel frame.

### FULL SURFACE LIGHTING

Low energy, dimmable LED lights provide superb illumination of the entire cooking surface.

## SPECIFICATIONS

### Accessories (included)

Aluminium filter	792577
Chimney extension	792492
Eave ducting kit	PD-RHK150E
Recirculation carbon filter	792481
Recirculation diverter	792560
Roof ducting kit	PD-RHK150T
Side wall ducting kit	PD-RHK150W

### Fan ratings

Maximum air movement	780m <sup>3</sup> /hr
----------------------	-----------------------

### Installation and cleaning

Dishwasher safe filters	2
Ducted	Top extraction
Recirculation	Optional - top extraction
Stainless steel filter cover	•

Two piece height adjustable •

### Performance

Extraction type	Perimeter
Fan speeds	3
Filter type	Mesh with perimeter
Number of filters	2

### Power requirements

Motor power	240W
Supply frequency	50Hz
Supply voltage	220 – 240V

### Product dimensions

Depth	500mm
Height	595 – 1035mm
Width	598mm

### Product information

Control type	Capacitive touch
--------------	------------------

### Ventilation features

Auto-off/Run-on timer	•
Dimmable lights	•
Filter cleaning alert	•
Light type	LED strip
Wi-Fi connectivity	•

### Warranty

Parts and labour	2 years
------------------	---------

SKU 50189

The product dimensions and specifications in this page apply to the specific product and model. Under our policy of continuous improvement, these dimensions and specifications may change at any time. You should therefore check with Fisher & Paykel's Customer Care Centre to ensure this page correctly describes the model currently available. ? Fisher & Paykel Appliances Ltd 2020

### Other product downloads available at fisherpaykel.com



Service & Warranty



Preliminary Specification Guide Rangehood



**A PEACE OF MIND SALE**

**24 Hours 7 Days a Week Customer Support**

**T 1300 650 590 W www.fisherpaykel.com**