

HOBD182DG

83CM LINEA INTEGRATED INDUCTION COOKTOP

MADE IN ITALY

Since 1948



AUTOMATIC EXTRACTION FUNCTION

The design of the HOBD cooktop is minimalism in its purest form. A unique piece of technology with a powerful integrated extractor fan, capable of instantly removing odours. The automatic extraction function allows the rangehood to automatically change speed in accordance with power level - selecting the most appropriate extraction level for a variety of cooking styles.

ECO LOGIC ADVANCED

Save energy without compromising cooking results with the Eco Logic Advanced limitation system, enabling a minimum power draw of 2.8kW.

FLUSH CAST IRON GRILL

A cast iron grill lies at the centre of the HOBD hob, protecting the powerful integrated extractor fan. With no difference in the height across its surface, the glass ceramic cooktop is completely flush, so pans can be moved across it without encountering any obstacles. A few centimetres under the surface, the extraction motor instantly removes cooking odours and vapours much faster than a traditional hood.

POWER BOOST IN EACH ZONE

Smeg's HOBD induction cooktop features the power boost function in each zone. Boost provides temporary additional power to zones when an even more intense heat is required and is ideal for heating large quantities of water rapidly.



COOKTOP FEATURES

EAN	8017709331856
Dimensions	830mmW x 520mmD x 230mmH
Finish	Neptune Grey
Installation	Topmount/fully flushed
Cutout	765-766W x 482-483mmD (refer to technical drawing)
Capacity	4 zones Front left: 22.0 x 19.7 cm 2100W - boost 3000W Rear left: 22.0 x 19.7 cm 2100W - boost 3000W Rear right: 22.0 x 19.7 cm 2100W - boost 3000W Front right: 22.0 x 19.7 cm 2100W - boost 3000W Multizone left: 39.5 x 22.0 cm, 3000W - boost 3700W Multizone right: 39.5 x 22.0 cm, 3000W - boost 3700W
Functions/features	Melting function Pause function Recall function
Timer	End of cooking acoustic alarm Residual time indicator 4 x timers 1 x minute minder
Controls	Back-lit white LED touch control 9 power levels + boost
Safety	Pan detection Automatic cut-off Residual heat indicator Control lock Child lock
Power	220-240V, 50/60Hz 7,620 W 33A Connection
Pan size	Automatic pan size recognition (minimum 11cm)
Included accessories	Extraction and charcoal filter kit
Warranty	Five years parts and labour

RANGEHOOD FEATURES

Motor	1 x 220W
Max airflow	700m ³ /hr (IEC 61591)
Noise rating	51-72dBA (IEC 60704-2-13)
Speeds	8 + 2 intensive
Functions	Autovent Delay function
Ducting options	Duct to atmosphere / recirculate — 150mm diameter ducting required
Included accessories	Stainless steel anti-grease filter Regenerable charcoal filters

HOBD182DG

83CM LINEA INTEGRATED INDUCTION COOKTOP

MADE IN ITALY

Since 1948

TOP MOUNT:

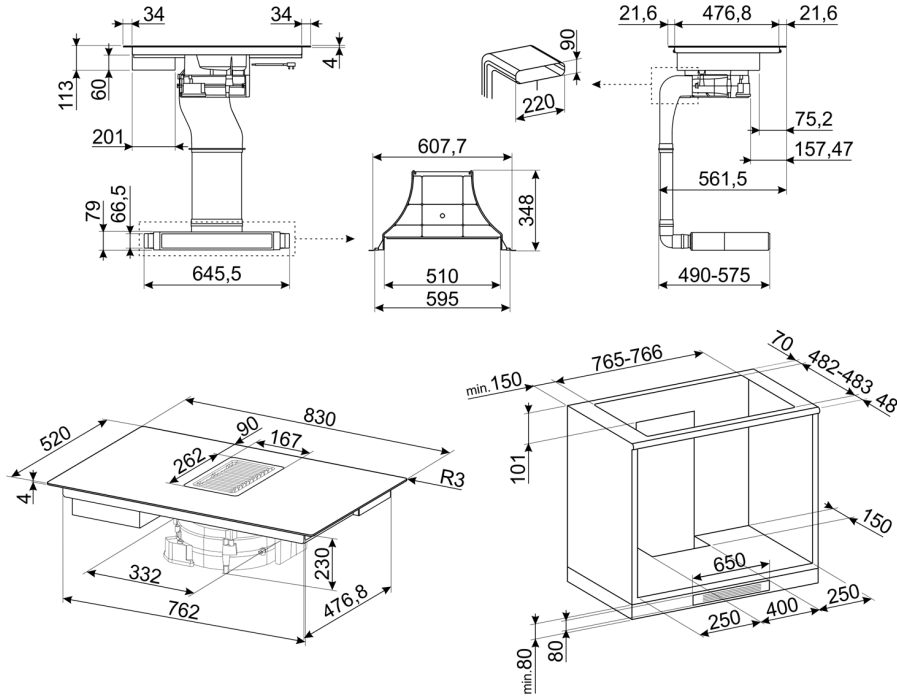

FLUSH MOUNT:

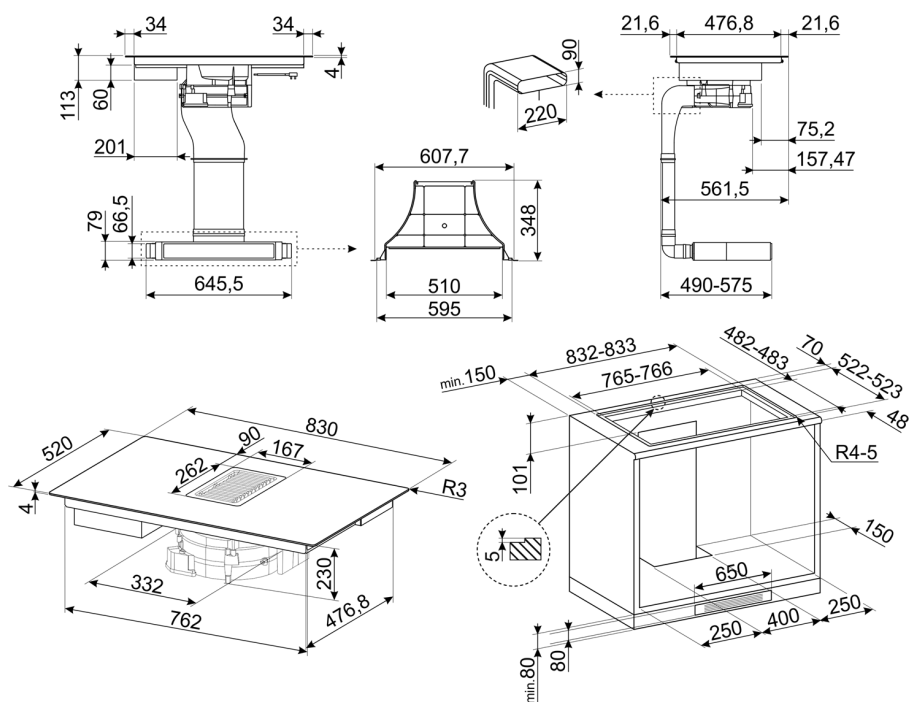

PLEASE NOTE: drawings are not to scale. They are to assist only.

WARNING: technical specifications and product sizes can be varied by the manufacturer without notice.

Cutouts for appliances should only be by physical product measurements. The above information is indicative only.