

# FONTAS II SIGLRANIT™

3 in 1 filter high arch tap

# BLANCO

FONTASAF Anthracite



## Key Features

### European design

European styling and engineering

### Ceramic Disk Cartridge

Durable and long lasting ceramic disk technology

### 2 Levers

Separate lever for filtered water

### 3 in 1 Tap

3 in 1 mixer tap with cold and warm water lever on the right, filtered water lever on the left, space saving and practical

### High Arch and 360° swivel

The high arched neck and 360° swivel will allow you to clean dishes and fill pots and vases with ease

## Specifications

### Material:

Anthracite

### WELS Rating:

5

### Litres Per Minute:

5

### Recommended Pressure:

300kPa

### Min Pressure:

150kPa

### Max Pressure:

1000kPa

### Dimensions:

300mm total height

205mm spout length

267mm spout height

### Spout Swivel:

360°

### Mounting Hole:

Ø 35 mm tap hole required

### Filter Supplied:

Yes ( Recommended to replace minimum every 12 months - varies by location and water hardness)

### Warranty:

10 years

## Line Drawings

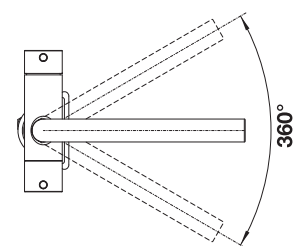
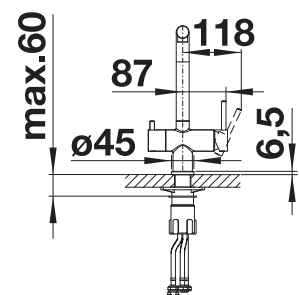
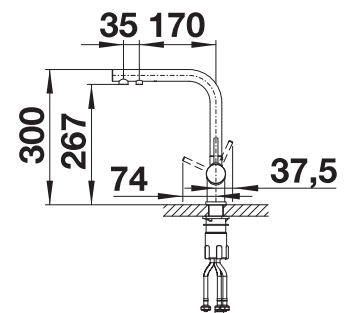

Note: Measurements are within 2 - 3mm of factory tolerance. It is advisable to check dimensions of physical product when measuring for installations and before doing any cut outs.  
\*Due to continual product development the information provided is not final and may be subject to change.