

FAB REFRIGERATION

FAB32 50'S STYLE RETRO REFRIGERATOR

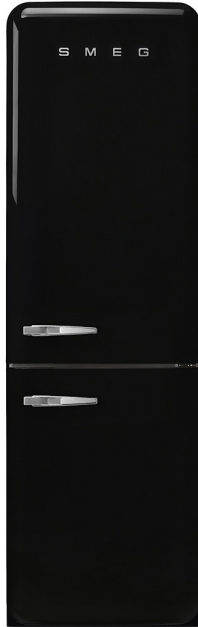

Finish	Orange, Pastel blue, White, Blue, Black, Pink, Red, Silver, Pastel green, Lime green, Cream
Dimensions	600mmW x 1968mmH x 768mmD (includes handle)
Gross Capacity	Refrigerator: 234L Freezer: 97L Total: 331L

REFRIGERATOR

No. Shelves	2 x Quick chill glass 1 x Deli cover 1 x Crisper cover
-------------	--

No. Drawers	1 x Crisper drawer 1 x Deli drawer
-------------	---------------------------------------

Lighting	LED
----------	-----

Inner Fridge Door)

No. Shelves	1 x shelf with transparent cover 1 x adjustable with wire support 1 x bottle shelf with wire support
-------------	--

FREEZER

No. Shelves	2
No. of drawers	3 x plastic drawers
Accessories	1 x Fast freezing compartment
Defrost	Total Frost Free

Performance

Energy Consumption	260kWh/year
Star Rating	4.5 Star
Noise	37 dBA
Power	220-240V, 50/60Hz 10A (3-pin plug)
Warranty	5 years parts and labour



PERFECT BLEND OF ARTISTRY & FUNCTIONALITY

Like other timeless designs, the original Smeg FAB refrigerator is more than just a mere fridge. It's the focal point of the kitchen, bringing together unquestionable style and premium performance. Always evocative and eclectic, FAB fridges have become standard bearers for "Made in Italy" design all over the world with their inimitable blend of artistry and functionality.

TEMPERATURE CONTROL WITH LED DISPLAY

Set the optimal conditions for a variety of food and beverages with Smeg's electronic temperature control display. At the touch of a button, accurately monitor temperature for fridge and freezer with a simple to use LED display.

LIFE PLUS 0°C DRAWER

This drawer provides a controlled temperature zone for better and longer preservation of perishable food such as meat, fish and dairy products.

MULTI-FLOW COOLING SYSTEM

MultiFlow accelerated air circulation technology provides a constant temperature in all section of the refrigerator, except for the Fresh Plus Zone where the temperature is maintained around 0°C. Compared to conventional systems, the multi-flow cooling system delivers the most efficient cooling of food, keeping the freshness, aroma, and nutrients of fruit, vegetables, and meat much longer.



FAB32

50'S STYLE RETRO REFRIGERATOR

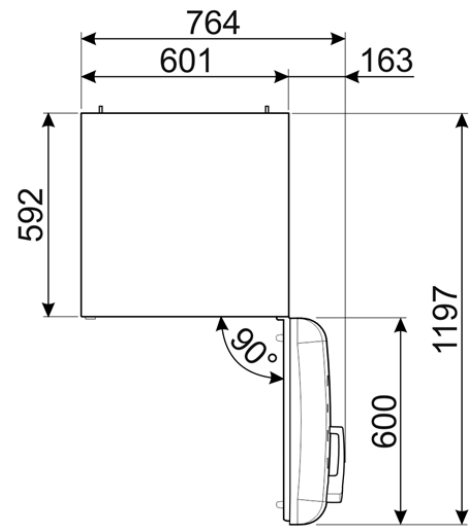
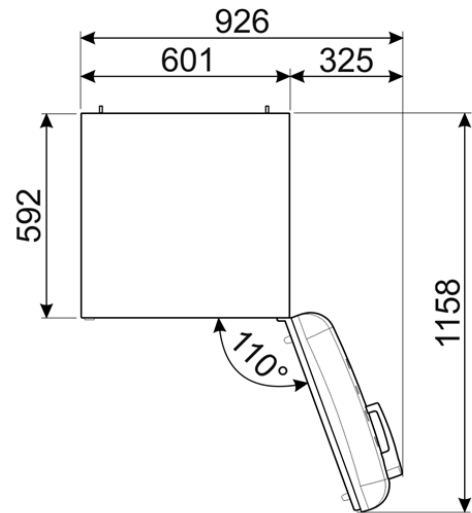
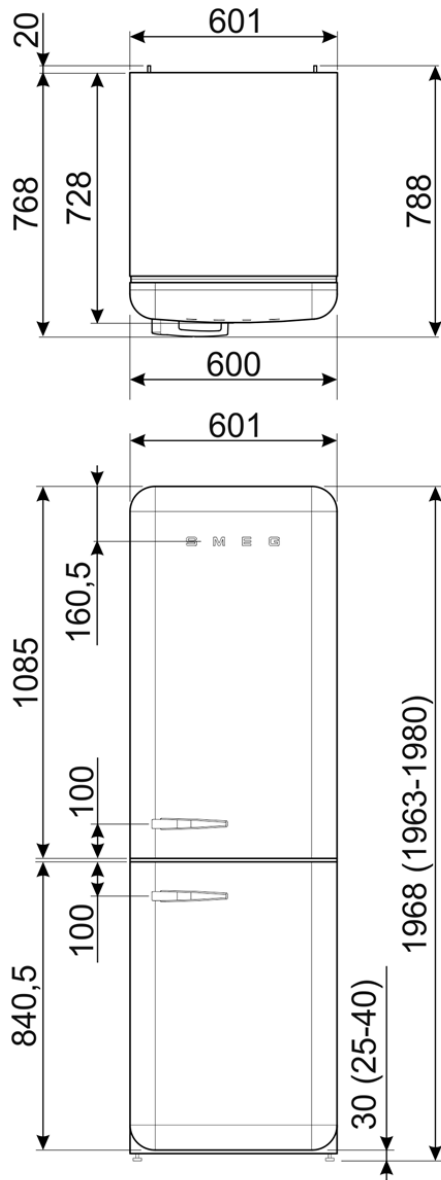

PLEASE NOTE: drawings are not to scale. They are to assist only.
WARNING: technical specifications and product sizes can be varied by the manufacturer without notice.
Cutouts for appliances should only be by physical product measurements. The above information is indicative only.

FAB REFRIGERATION

FAB32
50'S STYLE RETRO REFRIGERATOR



FAB32LBL3AU
FAB32RBL3AU
Black



FAB32LSV3
FAB32RSV3
Silver



FAB32LCR3AU
FAB32RCR3AU
Cream



FAB32LRD3AU
FAB32RRD3AU
Red



FAB32LPG3AU
FAB32RPG3AU
Pastel green



FAB32LPB3AU
FAB32RPB3AU
Light blue



FAB32RLI3
Lime green



FAB32LPK3
FAB32RPK3
Pink



FAB32RBE3
Royal blue



FAB32LOR3
FAB32ROR3
Orange



FAB32LWH3AU
FAB32RWH3AU
White

L: left hinge | R: right hinge

ID190708