

>> **EV-9UCQ** rangehood/**UNDER MOUNT**/90cm

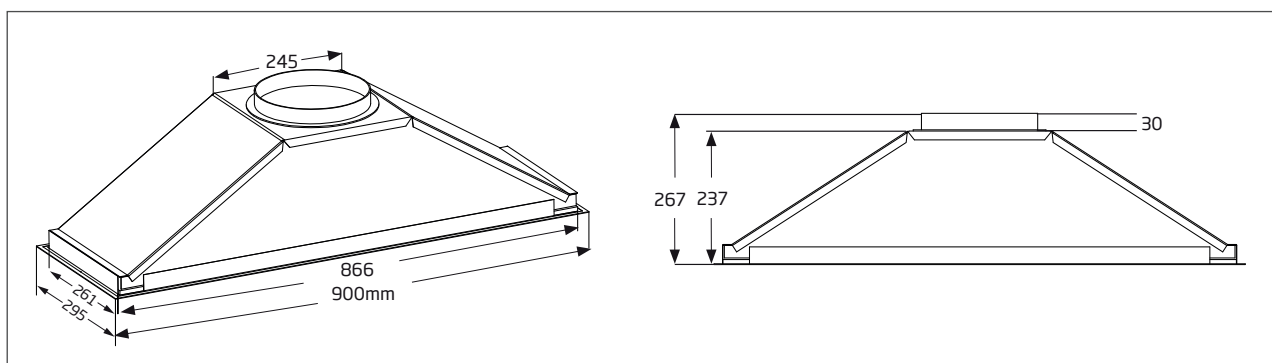

- **easy to use** - stainless steel undermount rangehood integrates seamlessly with kitchen cabinetry, creates a functional, practical kitchen.
- **powerful silent extraction** - externally mounted motor for effective extraction of steam, smoke, and odours, leaves kitchen air fresher.
- **strong lighting** - Incandescent lighting over the cooking zone.
- **mesh filters** - aluminium, dishwasher safe.

Isodrive® Power Options

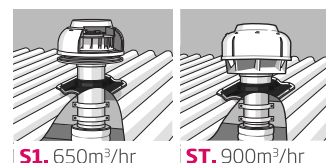

Description	Technical data	Motor power
<ul style="list-style-type: none"> stainless steel finish silent motor system manual controls single speed level incandescent lighting aluminium, dishwasher safe filters 2 Year Warranty on rangehood 10 Year Warranty on Isodrive motor 	<p>EV-9UCQ</p> <ul style="list-style-type: none"> dimensions: (W x D) 900 x 295 mm 3 x aluminium mesh filters 2 x 25W incandescent light bulbs 	<ul style="list-style-type: none"> S1 - single external motor <ul style="list-style-type: none"> - 650 m³/h airflow - 150mm flexi ducting (4m) - install roof/wall/eaves ST - single external motor <ul style="list-style-type: none"> - 900 m³/h airflow - 200mm flexi ducting (6m) - install roof/wall

address: 8/3-4 Anzed Court, Mulgrave, Victoria 3170
 phone: 1300 881 693
 email: sales@schweigen.com.au
 web: www.schweigen.com.au