



Product Features

Motor Type	Remote (Inline or Wall Mounting)
Filtration Type	Metallic Grease Filter x 3
Controls	Touch Controls (Remote Control Included)
Speed Settings	3 Speed + Boost
Timer Function	15 Min Auto Shut-Off
Ducting	200mm Circular Outlet + 5m of flexible ducting supplied
Included Accessories	90° Elbow Wall Vent (Inline Motor Only)
Other	N/A

* Maximum distance from cooktop 150cm

Dimensioned Drawings

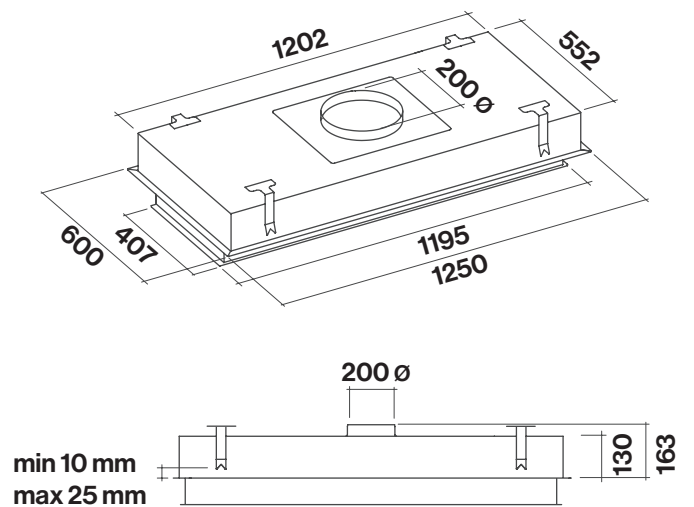

Model Code	Hood Mounting	Size	Motor Output	Lighting	Finish
F9ES12W1-IN1300 •	Ceiling	120cm	1300 m ³ /hr	LED 4 x 14 W (5500 K)	White Steel
F9ES12W1-EW1500 •	Ceiling	120cm	1500 m ³ /hr	LED 4 x 14 W (5500 K)	White Steel

Special Order •