

DWAFI6D15T3

60CM DIAMOND SERIES FULLY-INTEGRATED DISHWASHER - TALL TANK

MADE IN ITALY

Since 1948



PLANETARY WASH SYSTEM

Smeg's world-first planetary wash system features a single wash arm which rotates around two axes, significantly increasing wash pattern density and cleanliness. Angled jets reach in between every piece in the dishwasher for the most thorough and energy-efficient wash to date.

SANITISE WASH PROGRAM

Within two hours, this program can clean your dishes, baby bottles, and cutting boards whilst removing 99.9% of germs (VDE tested).

ACTIVE ACQUASTOP

By electronically determining when and how much water to let into the dishwasher, Smeg's Active Acquastop automatically controls the water feed at the tap. This ensures there is no pressure in the inlet hose, eliminating the risk of bursting.

5 STAGE FILTRATION SYSTEM

The ultimate dishwasher filtration system maintains a high quality wash by trapping food, thus preventing it from re-entering the wash system.

DRY ASSIST

Smeg's Dry Assist system opens the door slightly at the end of the wash program. This option allows the residual heat of the machine to dry the load, including hard-to-dry items naturally and thoroughly, without the consumption of additional energy.

EAN 8017709297138

Dimensions	598mmW x 858mmH x 568mmD
Finish	-
Total functions	10 + 5 Functions
Capacity	15 Place settings
Warranty	Five years parts and labour

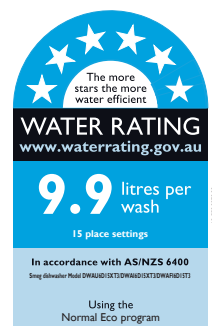
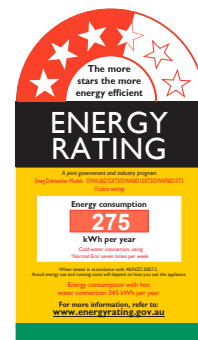

DWAFI6D15T3

60CM DIAMOND SERIES FULLY-INTEGRATED DISHWASHER - TALL TANK

MADE IN ITALY

Since 1948

DISHWASHER FEATURES

Size	598mmW x 858mmH x 568mmD
Capacity	15 Place settings
Type	Fully-integrated - Tall tank
Finish	-
Display	LED
Programs	10 + 5 Functions
End of cycle indicator	On display, with acoustic signal
Baskets	3 Levels
Wash system	Planetary Wash System
Water softener	Yes – electronically adjustable
Temperatures	38°, 45°, 50°, 55°, 65°, 70°, 75°C
Features	Internal LED lights Aquatest turbidity sensor ½ Load FlexiZone FlexiDuo basket Fully adjustable baskets EasyGlide System Self balancing hinges Inverter Motor
Water connection	Hot or cold water connection (60°C Max)
Timer	Up to 24 hours, with automatic soak
Filtration	Stainless steel 5 stage filter
Drying	Natural condenser drying with Dry Assist
Safety	Active Acquastop
Noise	42 dBA
Energy Usage	275 kWh/year
Energy Rating	3.5 Star
Water usage	9.9 Litres
Water Rating	6 Star
Power	230–240V, 50/60 Hz 1800W 10A
Warranty	Five years parts and labour

DISHWASHER PROGRAMS

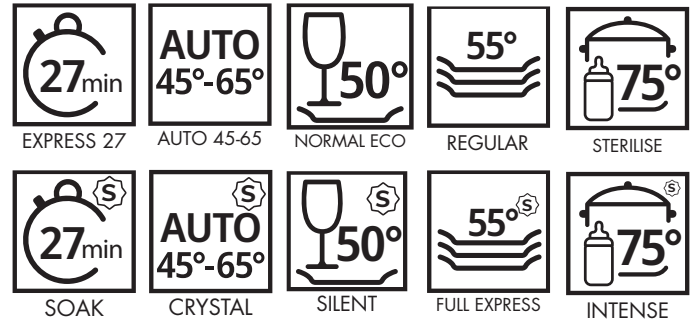

DISHWASHER FUNCTIONS

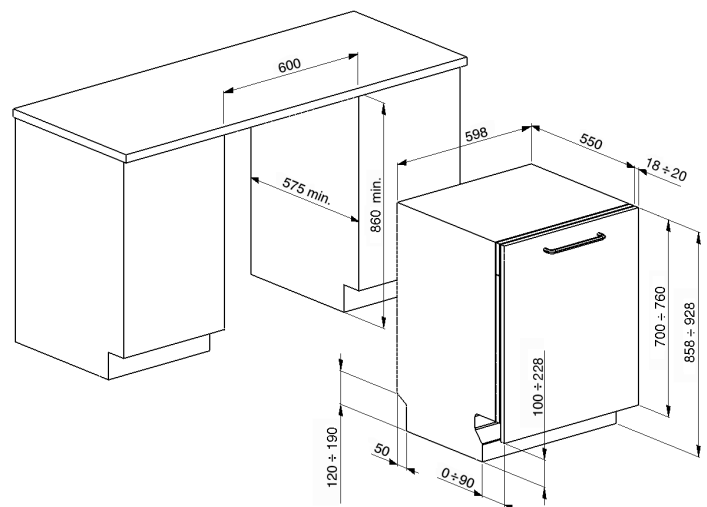
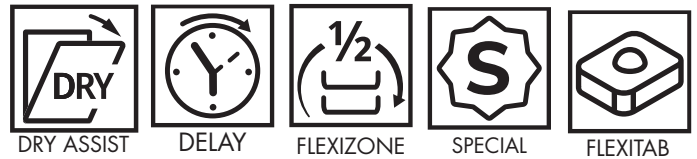

DWAFI6D15T3

60CM DIAMOND SERIES FULLY-INTEGRATED DISHWASHER - TALL TANK

MADE IN ITALY

Since 1948



Dimensions	598mmW x 858mmH x 568mmD
Power	230-240V, 50/60 Hz 1800W 10A
Warranty	Five years parts and labour

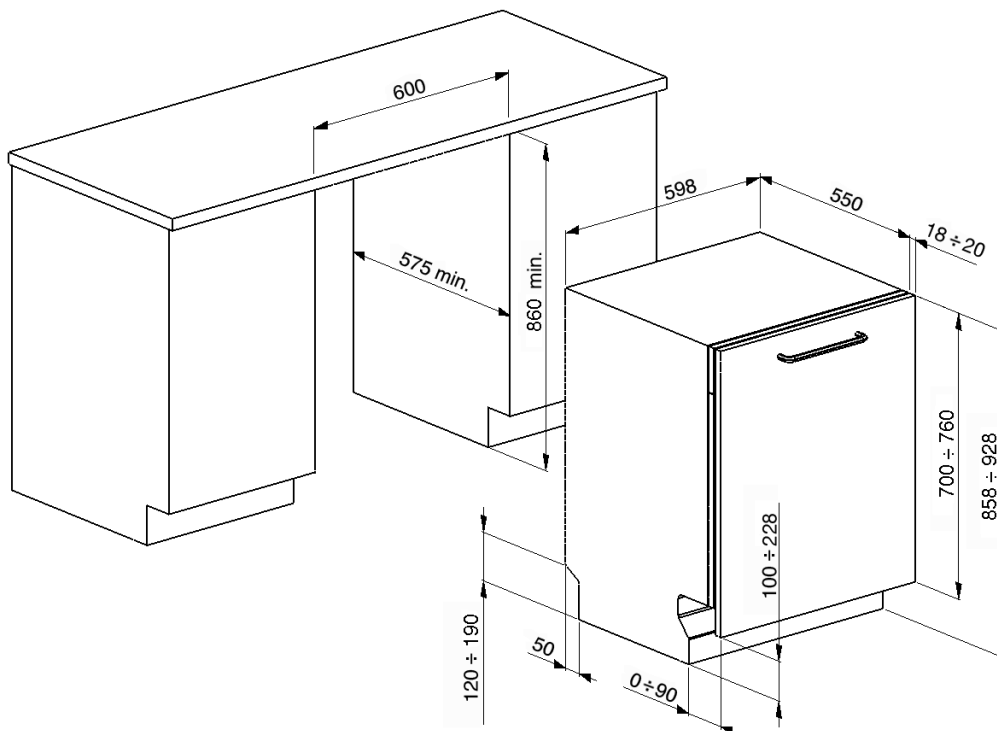

PLEASE NOTE: drawings are not to scale. They are to assist only.

WARNING: technical specifications and product sizes can be varied by the manufacturer without notice.

Cutouts for appliances should only be by physical product measurements. The above information is indicative only.