



Product Features

Motor Type	Remote (Recirculating or Inline)
Filtration Type	Top Filter x 2 Perimeter Suction
Controls	Touch Controls (Remote Control Optional)
Speed Settings	3 Speed + Boost
Timer Function	15 Min Auto Shut-Off
Ducting	200mm Circular Outlet
Included Accessories with Inline Motor	90° Elbow Wall Vent 5m Flexi Ducting
Included Accessories with Recirculating Motor	Carbon.Zeo Filter Rectangular Vertical Elbow Rigid Rectangular Ducting Base Board Vent

* Maximum distance from cooktop 150cm

Dimensioned Drawings

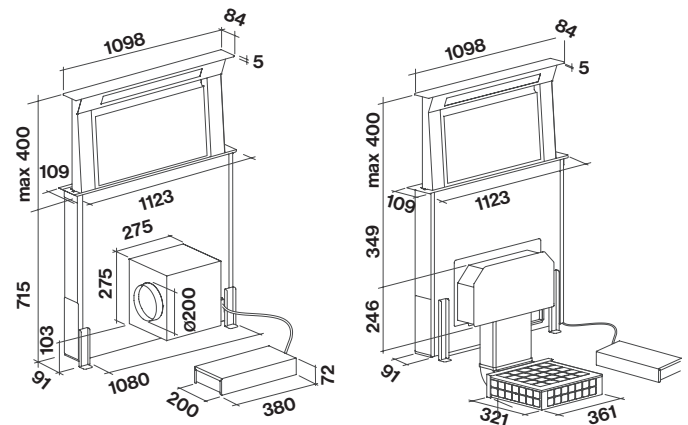

BASE BOARD VENT

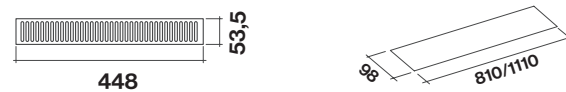

Model Code	Hood Mounting	Size	Motor Output	Lighting	Finish
F8DD12B1-IN1300	In-Bench	120cm	1300 m ³ /hr	LED Strip 10W	Black Glass
F8DD12B1-IN950	In-Bench	120cm	950 m ³ /hr	LED Strip 10W	Black Glass
F8DD12B1-UC600	In-Bench	120cm	600 m ³ /hr	LED Strip 10W	Black Glass
F8DD12S1-IN1300 •	In-Bench	120cm	1300 m ³ /hr	LED Strip 10W	Stainless Steel
F8DD12S1-IN950	In-Bench	120cm	950 m ³ /hr	LED Strip 10W	Stainless Steel
F8DD12S1-UC600 •	In-Bench	120cm	600 m ³ /hr	LED Strip 10W	Stainless Steel

Special Order •