

DOUBLE OVENS

DOSPA6395X 60CM CLASSIC THERMOSEAL PYROLYTIC DOUBLE OVEN



THERMOSEAL

The seal of Smeg's quality, technical excellence and taste: succulent roasts, crisp pastry and impressive baking is achieved in Smeg's unique, perfectly controlled cooking environment. Thermoseal maintains the perfect atmospheric balance in the cavity for optimum cooking conditions.



PYROLYTIC CLEANING

Smeg's pyrolytic cycle locks the door and heats the oven to around 500°C. This process carbonises any food residue or burnt-on grease to a small amount of ash, which can be simply wiped away with a damp cloth. Smeg also has Eco Pyro - the low energy option.



SMARTSENSE PLUS

Smeg's SmartSense Plus provides a foolproof, step-by-step guide to cooking. The large TFT colour display is legible without reading glasses, and so simple to follow. SmartSense Plus also has 50 guided cooking programs and you can also save 10 of your most-used favourites.



EVER CLEAN ENAMEL

The superior quality of Smeg's patented Ever Clean enamel, which is highly durable and easy to clean, is the result of nearly 70 years of enameling expertise; ensuring long-life performance of every Smeg oven.



COOL DOOR TECHNOLOGY

Smeg's Cool Door system is a combination of technologies which is driven by a 22 blade tangential fan and includes a heat exchange baffle system. It draws cool air up through the panes of heat-reflective glass in the door, making it safe to the touch even when the oven is at pyrolytic temperatures of around 500°C.

EAN

8017709207786

Finish	Fingerprint proof stainless steel Eclipse high visibility black glass
Total functions	17 + 50 SmartSense Plus auto menus + 4 (Aux oven) incl. Sabbath mode, defrost, proving and keep warm
Display	TFT
Capacity	Main oven 79L Aux oven 41L
Cooking levels	Main oven 5 Aux oven 2
Thermostat	Main oven 30 - 280°C Aux oven 50 - 270°C
Installation	Flush or wallmount
Programmability	Fully programmable
Cleaning	Smeg Ever Clean enamel, Pyrolytic / ECO Pyrolytic
Lighting	Main oven 1 x 40 Watt halogen Aux oven 1 x 40 Watt halogen
Supplied accessories	2 x Chrome grill insert 3 x Chrome shelves 1 x 20mm enamelled baking tray 2 x 40mm enamelled baking tray 1 x Partial telescopic guides
Optional accessories	PRTX - Pizza Stone PPR2 - Gourmet Cooking Stone PALPZ - Single-handle pizza paddle SSDPLUS - Baking Dish GT1P-1 - Partial telescopic guides GT1T-1 - Total telescopic guides
Safety	Cool Door technology, thermal protection system, child safety lock, controls lock
Dimensions	597mmW x 884mmH x 567mmD
Power	220-240V, 50/60Hz 5700W 25A current
Warranty	Two years parts and labour

DOUBLE OVENS

DOSPA6395X
60CM CLASSIC THERMOSEAL PYROLYTIC DOUBLE OVEN

FUNCTIONS (Main Oven):



FUNCTIONS (Aux Oven):

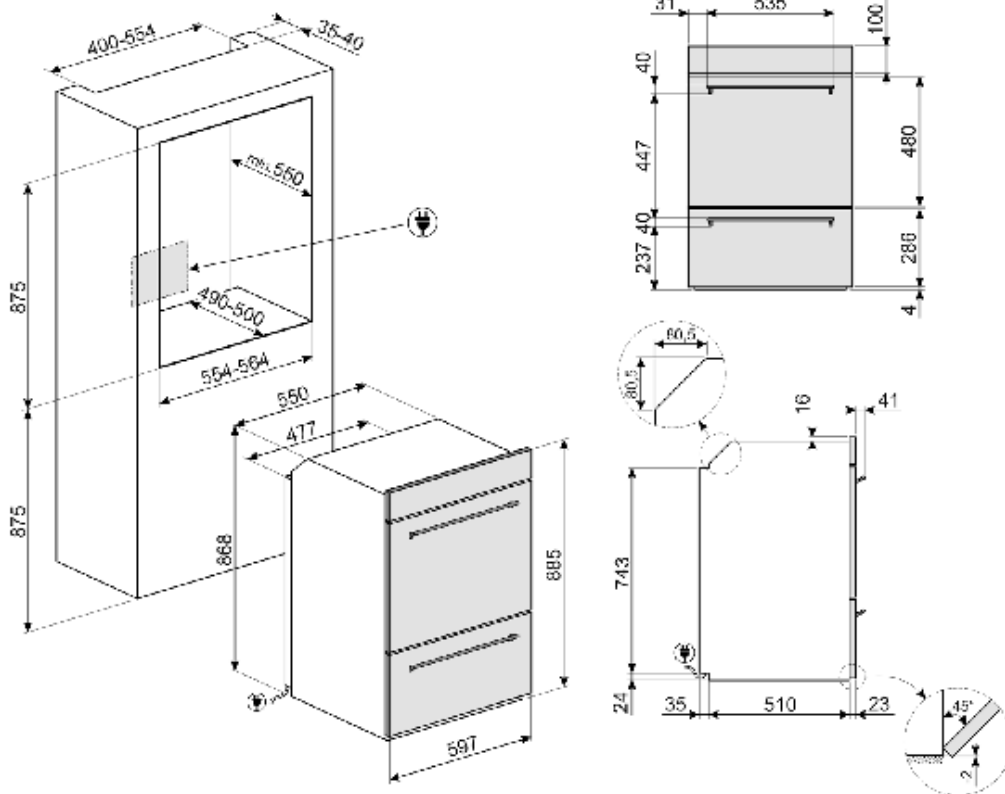

PLEASE NOTE: Drawings are not to scale. They are to assist only.

CABINETRY: Cut-outs are indicated for proud mounting. For flush mounting please refer to a specialist installer.

VENTILATION: Ovens and compact ovens require a 35-40mm ventilation gap at the rear of the cabinet.

WARNING: Technical specifications and product sizes can be varied by the manufacturer, without notice. Cutouts for appliances should only be by physical product measurements. The above information is indicative only.