

**Series 8, downdraft ventilation, 80 cm, clear glass  
DDW88MM66**



DSZ1WW1B6 Clean Air Plus odor filter (replacement), DSZ1WW1I6 Clean Air Plus recirculation kit, DSZ1WW1J1 Long Life recirculation kit, DSZ1WW1M1 Installation kit remote motor, DSZ8WW1Y2 Mounting kit for seamless installation, DZZ1WW1X1 Flat duct adapt.round 90° DN150 Metal, DZZ1XX1X1 Aluflex pipe cyl. 150, HEZ9VDSB1 90° flat duct bend horizontal, HEZ9VDSB2 90° flat duct L vertical, HEZ9VDSI0 Adapter round-flat, HEZ9VDSI1 90° Adapter round-flat, HEZ9VDSM1 Straight tube 500mm, HEZ9VDSM2 Straight tube 1000mm, HEZ9VDSS1 Connector sleeve (female)

**GlassDraft module: perfect extraction directly behind the cooktop, regardless of pot height and pot position.**

- **Decorative LED Illumination:** customizable LED lighting for your kitchen.
- **Guided Air Technology:** perfect extraction performance regardless of pot height and position.
- **Cooktop-based Hood Control:** convenient operation of the glass draft module via your hob.
- **Eco Silence Drive:** the powerful, energy-saving drive for hoods.

Typology: .....Downdraft  
 Length electrical supply cord: ..... 130.0 cm  
 Min. required niche size for installation (HxWxD): 703mm x 781.0mm x 123mm mm  
 Minimum distance above an electric cooktop: ..... 600 mm  
 Net weight: .....35.5 kg  
 Type of control: .....Electronic  
 Number of power settings: ..... 3-stages + 2 intensive settings  
 Max. air extraction: ..... 501 m<sup>3</sup>/h  
 Boost position output recirculating: .....525 m<sup>3</sup>/h  
 Max. air recirculation: ..... 416 m<sup>3</sup>/h  
 Boost position air extraction: ..... 775 m<sup>3</sup>/h  
 Noise level: .....62 dB(A) re 1pW  
 Diameter of air outlet: ..... 150 mm  
 Grease filter material: ..... Washable stainless steel  
 EAN code: .....4242005223657  
 Connection rating: ..... 300 W  
 Fuse protection: ..... 10 A  
 Voltage: ..... 220-240 V  
 Frequency: ..... 50; 60 Hz  
 Plug type: ..... Gardy plug w/ earthing  
 Installation typology: ..... Built-in



## Series 8, downdraft ventilation, 80 cm, clear glass DDW88MM66

### GlassDraft module: perfect extraction directly behind the cooktop, regardless of pot height and pot position.

- 80 cm wide
- Perfect for installation in an island or semi-island kitchen solution
- Suitable for ducted or re-circulated extraction
- For recirculated extraction Clean Air Plus recirculation kit (accessory) needed

#### Design

- The clear glass panel provides a glass edge lighting and is extendable via lift motor
- The appliance comes in an extraordinary glass design equipped with red edge lighting. Simply choose your favorite color via Homeconnect.
- Top Frame suitable for seamless installation to create a unity with cooktop for a pure surface design

#### Comfort

- Electronic metal soft-touch controls with LED indicators
- The user interface to the left provides extended functions
- The standard functions are located on the right-hand user interface
- TouchControl for power and light
- 3 power levels + 2 intensive levels
- Intensive setting with automatic switch back to previous setting
- Intensive operation automatic revert - 6min
- Automatic run on - 10 min
- Air Quality sensor
- Cooktop-based rangehood control (with matching cooktop)
- fully automatic rangehood

#### Cleaning

- Activate Guided Air to guarantee nearly perfect extraction, regardless of pot height and pot position on the cooktop
- Ambient Light
- The high quality filter cassettes with integrated metal grease filters are dishwasher safe.
- Dishwasher safe metal grease filters
- Saturation display for filters
- The filter service button automatically lifts filters into service position for easy removal
- The glass panel can be easily removed and cleaned

#### Connectivity

- Remote Monitoring and Control for connected home appliances and operation via smartphone or tablet
- The Home Connect functionality can be extended by integrating numerous applications from external cooperation partners (partnerships)
- Voice Control enabled via popular voice assistants
- interval function: available via Home Connect
- silence function: available via Home Connect

#### Performance

- Efficient BLDC-technology

- Extraction rate according to EN 61591 ø 15 cm: max. Normal use 501 m<sup>3</sup>/h. Intensive 775 m<sup>3</sup>/h
- Max. extraction rate: 775 m<sup>3</sup>/h
- Noise level according to EN 60704-3 exhaust air:
- Max. normal use:62dB(A) re 1 pW
- Intensive:70 dB(A) re 1 pW
- Noise min./max. Normal Level: 39/62 dB
- With the Clean Air Plus recirculation kit (available as accessory) your appliances reaches:
- Extraction rate in recirculation mode: Max. normal use:416m<sup>3</sup>/h
- Intensive:525m<sup>3</sup>/h
- Noise level in recirculation mode: Max. normal use:65dB(A) re 1 pW
- Intensive:70 dB(A) re 1 pW

#### Planning and installation information

- For seamless worktop installation a special accessory is required
- Suitable for installation into 90 cm cabinet
- Extension height 250 mm
- Appliance dimensions (HxWxD): 709 x 816 x 140 mm
- Installation dimensions (HxWxD): 703 x 781 x 123 mm
- 150 mm diameter pipe
- Electrical cable length 1.3 m
- For remote motor installation special accessory kit is needed
- Please reference the built-in dimensions provided in the installation drawing
- Combination with gas cooktops not allowed

#### Consumption Data

- Average Energy Consumption: 36.9 kWh/year
- Power rating: 300 W

## Series 8, downdraft ventilation, 80 cm, clear glass DDW88MM66

Measurements in mm

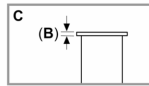
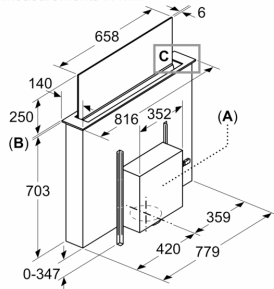

**A:** Installation of motor unit on front/rear or offset laterally with max. 3 m clearance (special accessory required)

Motor unit must always be accessible

**B:** 5.5 mm

Measurements in mm

**Standard, top-mounted installation**

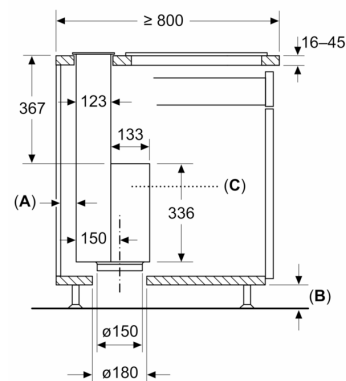

Standard: with worktop divider between downdraft and hob

**A:** ≥ 20 mm between the Guided Air suction area and a cabinet wall

**B:** ≥ 60 mm for air recirculation

≥ 100 mm for air extraction with ducting in the plinth

**C:** Motor unit must always be accessible

Measurements in mm

**Seamless, top-mounted installation**

(Special accessory required)

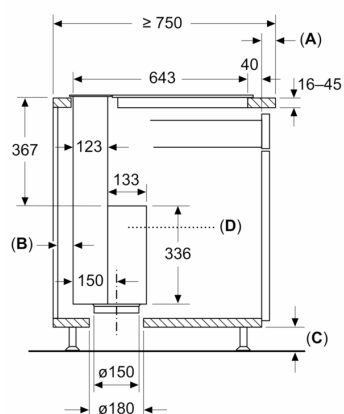

**A:** Worktop overlap to kitchen cabinet

**B:** ≥ 20 mm between the Guided Air suction area and a cabinet wall

**C:** ≥ 60 mm for air recirculation

≥ 100 mm for air extraction with ducting in the plinth

**D:** Motor unit must always be accessible

Measurements in mm

**Combination with electric hob  
Seamless, top-mounted installation**

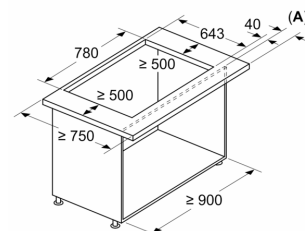

**A:** Worktop overlap to kitchen cabinet

Combination with gas hob is not possible

To prevent power loss, observe the following:

- Do not install upper cabinets or open shelf elements above the appliance
- Left/right distance between appliance and wall/adjacent upper cabinet min. 500 mm
- Distance between appliance frame and wall min. 50 mm

Measurements in mm  
**Combination with electric hob**  
**Standard, top-mounted installation**

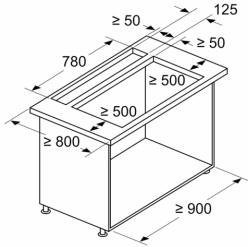

Standard: with worktop divider between downdraft and hob

Combination with gas hob is not possible

To prevent power loss, observe the following:

- Do not install upper cabinets or open shelf elements above the appliance
- Left/right distance between appliance and wall/adjacent upper cabinet min. 500 mm
- Distance between appliance frame and wall min. 50 mm

**Planning recommendation, air recirculation**

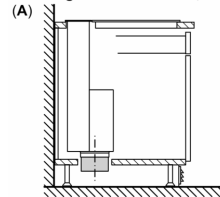

**A:** Exterior wall – U-value ≤ 0.5 W/(m²K)

Standard installation: Partially laid around the toe kick

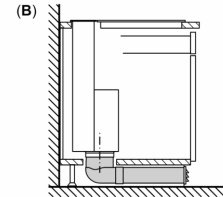

**B:** Exterior wall – U-value > 0.5 W/(m²K)

Installation with fully laid pipework to the toe kick for poorly insulated exterior walls or above cold floors

Measurements in mm  
**Combination with electric hob**  
**Seamless, top-mounted installation**

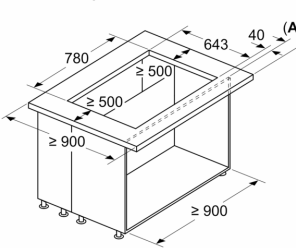

**A:** Worktop overlap to kitchen cabinet

Combination with gas hob is not possible

To prevent power loss, observe the following:

- Do not install upper cabinets or open shelf elements above the appliance
- Left/right distance between appliance and wall/adjacent upper cabinet min. 500 mm

Measurements in mm  
**Combination with electric hob**  
**Standard, top-mounted installation**

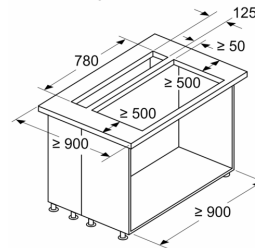

Standard: with worktop divider between downdraft and hob

Combination with gas hob is not possible

To prevent power loss, observe the following:

- Do not install upper cabinets or open shelf elements above the appliance
- Left/right distance between appliance and wall/adjacent upper cabinet min. 500 mm

Measurements in mm  
**Standard, top-mounted installation**

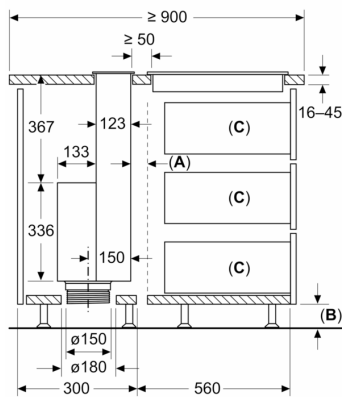

Standard: with worktop divider between downdraft and hob

**A:** Ventilation gap for hob

**B:** ≥ 60 mm for air recirculation

≥ 100 mm for air extraction with ducting in the plinth

**C:** Max. pull-out depth

Motor unit must always be accessible

Measurements in mm  
**Seamless, top-mounted installation**

**(Special accessory required)**

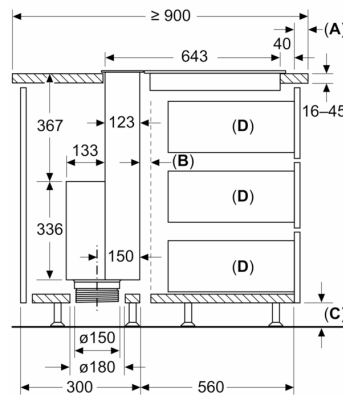

**A:** Worktop overlap to kitchen cabinet

**B:** Ventilation gap for hob

**C:** ≥ 60 mm for air recirculation

≥ 100 mm for air extraction with ducting in the plinth

**D:** Max. pull-out depth

Motor unit must always be accessible