

FREESTANDING SINGLE UNITS

CNPef 4516



LIEBHERR

Quality, Design and Innovation

LIEBHERR FREESTANDING SINGLE REFRIGERATOR/FREEZER CNPef 4516

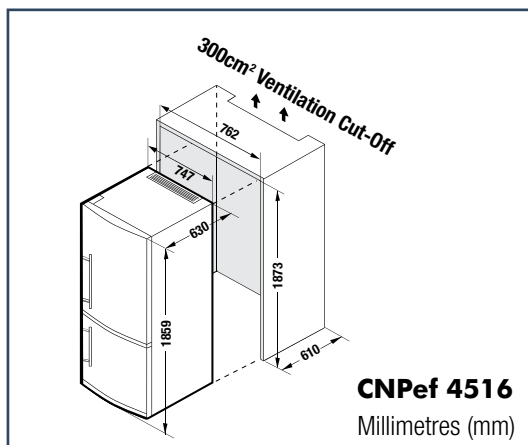

Model	CNPef 4516
Type Finish	FS SmartSteel (Doors Only)
Energy consumption (kWh/yr) Star rating	360 3.5
Compressors	1
Total capacity litres (L) - Gross Net	442 413
Refrigerator Gross (L) Refrigerator Net (L)	343 331
Freezer gross (L) Freezer Net (L)	99 82
MagicEye control system Display	SoftTouch LCD
Child proof setting for display & temperature	•
LED standard lighting (fridge)	•
SlimLine handle - integrated opening device	•
Door open warning signal	•
Temperature alarm	•
Malfunction warning signal	•

Refrigerator Features

Fruit & vegetable drawers on rollers	2
SuperCool	•
Sabbath mode	•
GlassLine shelves	•
Elegant holding columns	•
Egg tray	•
Automatic refrigerator defrosting	•
Stainless steel dry rear wall	•

Freezer Features

Freezer defrosting	Frost Free
FrostSafe system with transparent drawers	•
Freezer drawers	2
SuperFrost	•
VarioSpace	•
24hr freezing capacity (kg)	8

Technical Information

Default hinge	Right
Voltage (V) Rated Current (A)	220-240 1.5
Made in	Austria

KEY: FS = Freestanding. Cavity clearance for freestanding units please allow min. 50 mm above the unit if there is no ventilation cut-out. Door hinging either right or left hand must be nominated for this model.

Whilst every effort is made to ensure all specifications and information in this flyer are correct at time of printing, Andi-Co Australia Pty. Ltd. reserve the right to make changes without notification. Where actual appliance measurements, specifications and ratings are crucial, we recommend that the actual appliance installation instructions that accompany each appliance be checked. Andi-Co Australia will not be liable for any loss.

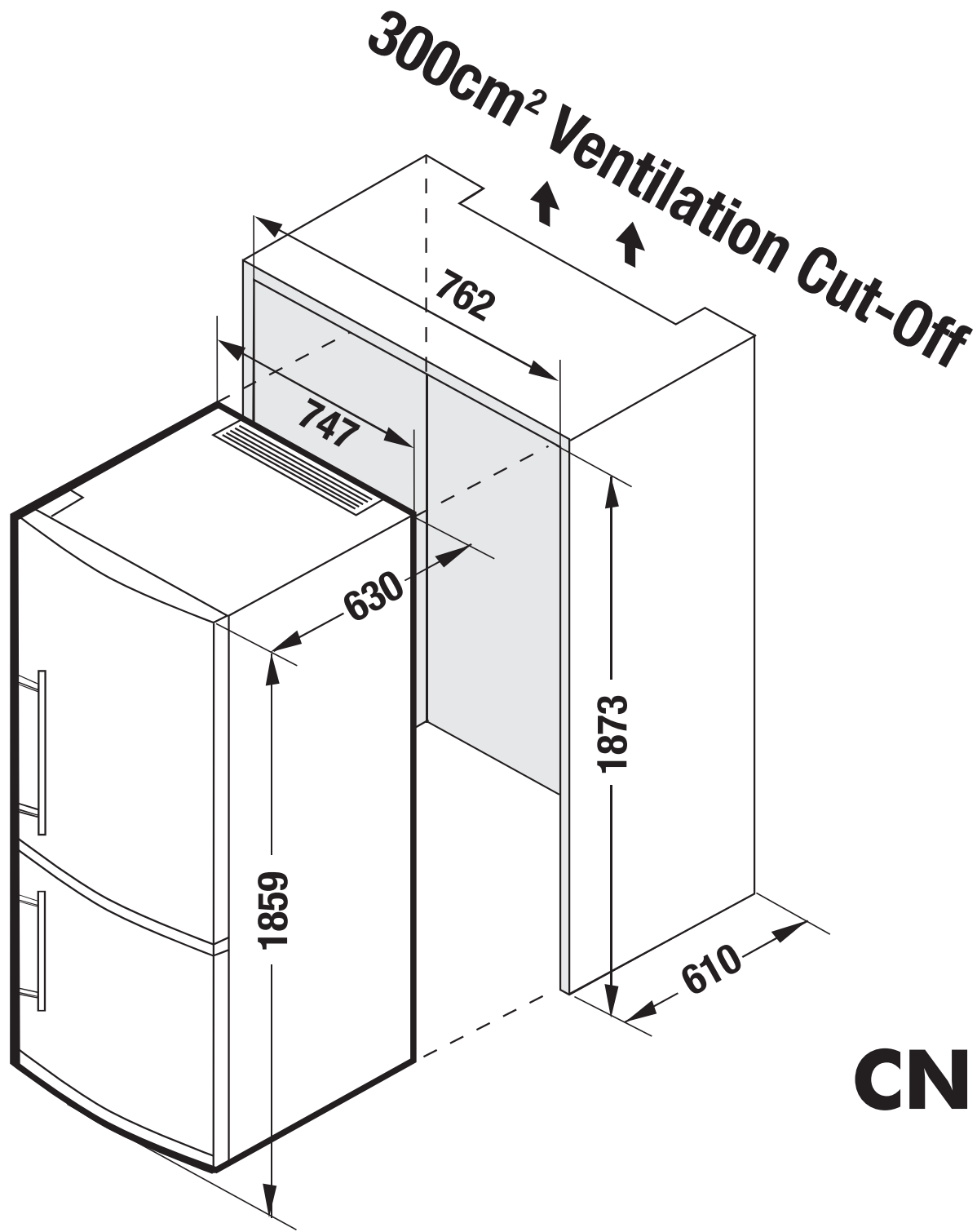

CNPef 4516
Millimetres (mm)