

**Series 8, Built-in vacuum drawer, 60
x 14 cm
BVE9101B1**



small, 50 x Vacuuming bag, big, 1 x Adaptor f. vacuuming outside the chamber, 1 x Vacuuming hose, 1 x Adaptor for bottle plugs, 3 x Plugs for vacuuming of bottles

HZG9AS00S Adapter

Vacuum drawer designed for preparing dishes for sous vide cooking. Vacuum-packed food that is steamed in a full steam appliance at a constant low temperature.

- **Vacuum drawer:** for the preparation of dishes for sous vide cooking.
- **99% vacuum:** perfect for vacuum sealing food.
- **Push-pull mechanism:** easy opening and closing thanks to a practical spring mechanism.

Net weight: 32.2 kg
Gross weight: 34.1 kg
Product image: 19882833_BVE9101B1_STP_def.jpg
EAN code: 4242005330133
Dimensions of the packed product (HxWxD): 230 x 660 x 660 mm
Included accessories: 50 x Vacuuming bag, small, 50 x Vacuuming bag, big, 1 x Adaptor f. vacuuming outside the chamber, 1 x Vacuuming hose, 1 x Adaptor for bottle plugs, 3 x Plugs for vacuuming of bottles



Series 8, Built-in vacuum drawer, 60 x 14 cm BVE9101B1

**Vacuum drawer designed for preparing
dishes for sous vide cooking.
Vacuum-packed food that is steamed in a
full steam appliance at a constant low
temperature.**

Vacuumping levels:

- 3 vacuumping levels for vacuumping in the chamber, max. 99%
- 3 vacuumping levels for vacuumping outside the chamber, max. 90%
- 3 heat sealing durations for different bag thicknesses and materials.

Design

- stainless steel cavity
- Illuminated TouchSelect controls
- Touch key operation

Convenience

- Cavity volume: 8 l
- Handleless push&pull opening mechanism
- Automatic connection recognition for vacuumping outside the chamber
- Drying program for vacuumping pump
- Locking mechanism prevents the drawer from closing accidentally.
- The vacuump bags are held by a clip safely in their position.

Accessories

- 1 x Adaptor f. vacuumping outside the chamber, 1 x Adaptor for bottle plugs, 3 x Plugs for vacuumping of bottles, 50 x Vacuumping bag, big, 50 x Vacuumping bag, small, 1 x Vacuumping hose

Safety and Environment

- Door contact switch

Technical Info

- Length of mains cable: 150 cm
- Total connected load electric: 0.32 KW
- Nominal voltage: 220 - 240 V

Dimensions

- Appliance dimensions (HxWxD): 140 mm x 595 mm x 542 mm
- Please reference the built-in dimensions provided in the installation drawing

**Series 8, Built-in vacuum drawer, 60
x 14 cm
BVE9101B1**

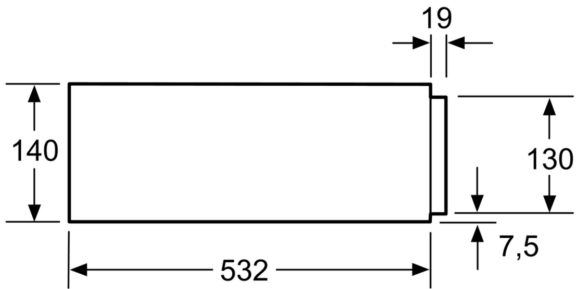

Compact ovens with an appliance height of 455 mm can be installed above a vacuum sealing drawer. An intermediate floor is not required.

measurements in mm

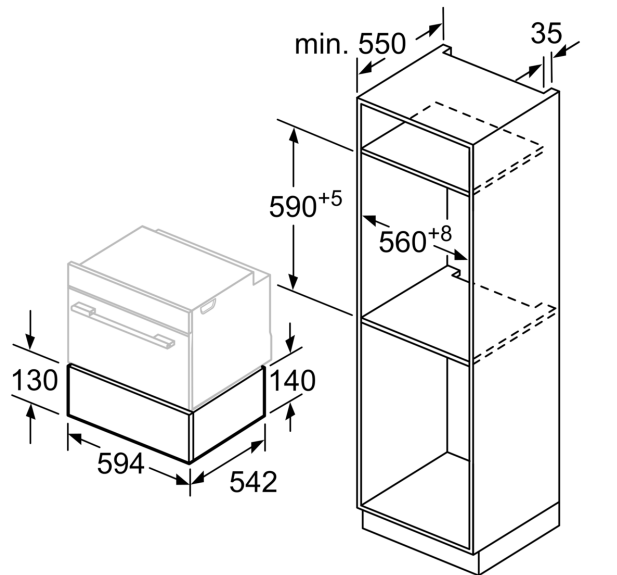

measurements in mm