

TECHNICAL DATASHEET

BASIS BFG 620 ONYX

Product Category	Sinks
Finish	Fragranite
Installation	Topmount
Range	BASIS
Model	BFG 620 ONYX
Warranty	50 Years



PRODUCT INFORMATION

Article Number	114.0276.140
Dimensions	860 x 500mm
Cabinet Base	800mm
Bowl Size	337 x 420 x 200mm
Bowl Radius	15mm
Cut-Out Size	840 x 480mm
Cut-Out Template	No
Waste Outlet	Semi Integrated Waste
Overflow	Yes
Tap Holes	Part Drilled
Remote Waste	No
Opposite Configuration	-
Accessories	1 2 3 4

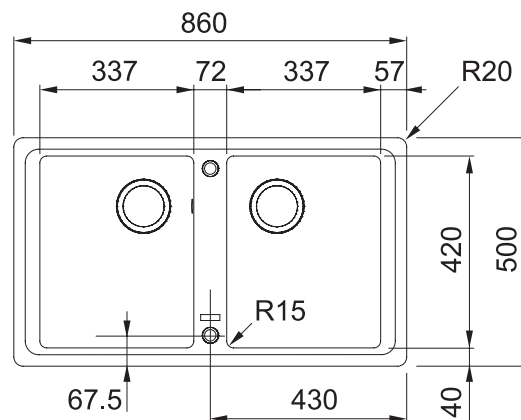

1 ACCESSORIES AVAILABLE **1** ACCESSORIES INCLUDED

ACCESSORIES

1



CB 600
Chopping Board

2



DB 784
Drainer Basket

3



RM 44
Rollamat

4

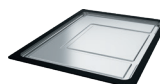

DT 360
Extension Drainer

FEATURES & BENEFITS



Food
Preparation
Centre



Franke
Granite



Remote-
Operated
Waste

LAST UPDATED: 18 JAN 2019

Make
it
Wonderful

FRANKE