

DGC 7840 HC Pro GRGR

Compact combination steam oven

for steam cooking, baking, roasting with wireless food probe + menu cooking.



EAN: 4002516629009 / Material number: 12087550

- 3-in-1 appliance - oven, steam and combination cooking for great flexibility and a wide range of cooking styles
- Fast and even steam distribution with DualSteam technology to seal in more nutrients and vitamins
- Perfect baking and roasting results with combination cooking using dry and moist heat
- Motorised lift-up control panel with SoftClose to access water and condensate container
- Easy thorough cleaning with HydroClean, an automatic self clean function allowing for food residue to be removed with ease leaving the cavity spotlessly clean.

Construction type and design	
Steam combination oven	•
VitroLine	•
Appliance Colour	Graphite Grey
Convenience features	
Rapid heat-up	•
Pre-heating	•
External steam generation	•
Oxygen sensor	•
Individual humidity settings in combination cooking	•
Menu cooking without transfer of taste	•
Prepare plated meals with "Mix & Match"	•
Food probe	Without cable
Automatic programmes with ability to make individual adjustments	•
Keeping warm	•
Crisp function	•
Operating modes	
Defrost	•
Automatic programmes	•
Combination cooking	•
Combination cooking with Fan plus	•
Combination cooking with Conventional heat	•
Combination cooking with grill	•
Steam cooking	•
Sous-vide	•
Reheat	•
Roast with moisture	•
Grill operating modes	•
Grill	•
Economy grill	•
Fan plus	•
Intensive bake	•
Cake plus	•
Conventional heat	•
Top heat	•
Bottom heat	•
Fan grill	•
Eco fan heat	•
Eco steam cooking	•
Plate warming	•
Special applications	•
User convenience	
Networking with Miele@home	•
Display	M Touch
MotionReact: light comes on when movement is detected	•
MotionReact: display comes on when movement is detected	•
MotionReact: audible signal is acknowledged when movement is detected	•
MultiLingua	•
Motorised lift-up control panel with SoftOpen/SoftClose	•

DGC 7840 HC Pro GRGR

Compact combination steam oven

for steam cooking, baking, roasting with wireless food probe + menu cooking.



EAN: 4002516629009 / Material number: 12087550

- 3-in-1 appliance - oven, steam and combination cooking for great flexibility and a wide range of cooking styles
- Fast and even steam distribution with DualSteam technology to seal in more nutrients and vitamins
- Perfect baking and roasting results with combination cooking using dry and moist heat
- Motorised lift-up control panel with SoftClose to access water and condensate container
- Easy thorough cleaning with HydroClean, an automatic self clean function allowing for food residue to be removed with ease leaving the cavity spotlessly clean.

Steam cooking on up to 3 levels at the same time	•
Automatic menu cooking	•
Steam reduction before end of programme	•
Polyphonic buzzers	•
Time of day display	•
Date display	•
Minute minder	•
Programmable start of cooking duration	•
Programmable end of cooking duration	•
Programmable cooking duration	•
Actual temperature display	•
Target temperature display	•
Buzzer when desired temperature is reached	•
Recommended temperature	•
User programmes	•
Sabbath programme	•
Individual settings	•
MotionReact proximity sensor	•
Efficiency and sustainability	
Power rating in off mode in W	0.5
Power rating in standby mode in W	1.0
Power rating in networked standby in W	2.0
Time until automatic switch to standby in min	20
Time until automatic switch to networked standby in min	20
Time until automatic switch to off mode in min	20
Cleaning convenience	
Stainless-steel oven interior with linen structure	•
Hinged grill element	•
External steam generator	•
HydroClean	•
Maintenance programmes	•
Soak programme	•
Rinse programme	•
Oven compartment drying programme	•
Quick-release side racks	•
Removable stainless-steel side racks	•
Automatic descaling	•
CleanGlass door	•
Steam technology and Water supply	
DualSteam	•
Steam generator power in kW	3.3
Fresh water container volume in l	1.4
Fresh water container behind motorised control panel	•
Condensate container behind motorised lift-up control panel with SoftClose	•
Drain filter	•

DGC 7840 HC Pro GRGR

Compact combination steam oven

for steam cooking, baking, roasting with wireless food probe + menu cooking.



EAN: 4002516629009 / Material number: 12087550

- 3-in-1 appliance - oven, steam and combination cooking for great flexibility and a wide range of cooking styles
- Fast and even steam distribution with DualSteam technology to seal in more nutrients and vitamins
- Perfect baking and roasting results with combination cooking using dry and moist heat
- Motorised lift-up control panel with SoftClose to access water and condensate container
- Easy thorough cleaning with HydroClean, an automatic self clean function allowing for food residue to be removed with ease leaving the cavity spotlessly clean.

Safety	
Appliance cooling system and touch-cool front	•
Safety switch-off	•
System lock	•
Vapour cooling system	•
Sensor lock	•
Technical data	
Oven compartment volume in l	48
No. of shelf levels	3
Appliance dimensions (W x H x D) in mm	595 x 456 x 572
Numbered shelf levels	•
Door hinge	Bottom
Oven light	BrilliantLight
Oven temperature regulation min. in °C	30
Oven temperature regulation max. in °C	230
Electronic steam oven temperature regulation min. in °C	40
Electronic steam oven temperature regulation max. in °C	100
Niche width min. in mm	560
Niche width max. in mm	568
Niche height min. in mm	450
Niche height max. in mm	452
Niche depth in mm	550
Appliance width in mm	595
Appliance height in mm	456
Appliance depth in mm	572
Weight in kg	40.2
Total rated load in kW	3.45
Voltage in V	230
Frequency in Hz	50
Number of phases	1
Fuse rating in A	16
Mains cable with plug	•
Length of supply lead in m	2
Accessories supplied	
Universal tray with PerfectClean	1
FlexiClip runners with PerfectClean	1
No. of perforated stainless-steel cooking container	2
No. of solid stainless-steel cooking containers	1
HydroClean cleaning agent	1
Descaling tablets	2

DGC 7840 HC Pro OBSW Installation diagrams

Installation in a tall unit

The furniture housing unit must not have a back panel fitted behind the building-in niche.

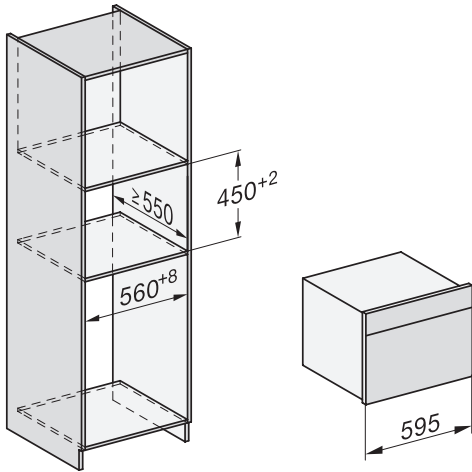

Installation in a base unit

When building the oven into a base unit underneath a cooktop, please also observe the installation instructions for the cooktop as well as the building-in height required for the cooktop.

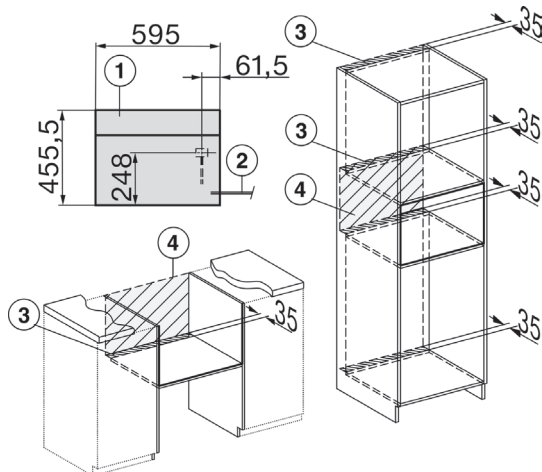

Side view

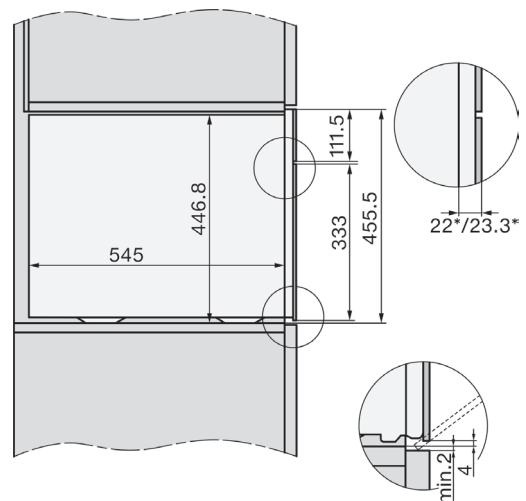

All dimensions are given in mm