

H 7840 BM

Speed oven

with a seamless design, Automatic programmes and food probe



- Large touch display with movement sensor – M Touch + MotionReact
- Easy cleaning – compartment with PerfectClean and linen structure
- Faster and more consistent results – Quick & Gentle
- Network-enabled WiFi appliance – Miele@home
- Get what you want in 1 easy step – Quick MW and Popcorn button

Model and design	
Built-in microwave combination oven	•
VitroLine	•
Appliance colour	Brilliant white
Convenience features	
Quick & Gentle	•
Rapid heat-up	•
Food probe	With cable
Keeping warm	•
Crisp function	•
Operating modes	
Defrosting	•
Automatic programmes	•
Automatic programmes	•
Auto roast	•
Grill operating modes	•
Grill	•
Fan plus	•
Intensive bake	•
Low temperature cooking	•
Microwave	•
Microwave + Auto roast	•
Microwave + Grill	•
Microwave + Fan plus	•
Microwave + Fan grill	•
Conventional heat	•
Bottom heat	•
Fan grill	•
Special applications	•

H 7840 BM

Speed oven

with a seamless design, Automatic programmes and food probe



<b>User convenience</b>	
Networking with Miele@home	•
Display	M Touch
MotionReact: light comes on when movement is detected	•
MotionReact: display comes on when movement is detected	•
MotionReact: audible signal is acknowledged when movement is detected	•
MotionReact: detection of cabinet fronts	•
SoftClose	•
MultiLingua	•
MyMiele	•
Help function	•
Popcorn function	•
Polyphonic buzzers	•
Timer functions	•
Time of day display	•
Date display	•
Minute minder	•
Programmable start of cooking duration	•
Programmable end of cooking duration	•
Actual temperature display	•
Target temperature display	•
Audible signal when target temperature is reached	•
Recommended temperature	•
Quick microwave	•
Sabbath programme	•
Individual settings	•
<b>Efficiency and sustainability</b>	
Residual heat utilisation	•
<b>Cleaning convenience</b>	
Stainless-steel oven compartment with linen-weave pattern	•
PerfectClean finish	•
Hinged grill heater element	•
CleanGlass door	•
<b>Safety</b>	
Appliance cooling system and touch-cool fronts	•
Safety switch-off	•
System lock	•
Sensor lock	•

H 7840 BM

Speed oven

with a seamless design, Automatic programmes and food probe



<b>Technical data</b>	
Oven compartment volume in l	43
No. of shelf levels	3
Oven light	1 LED spot
Temperatures in °C	30
Microwave power levels in W	80/150/300/450/600/850/1000
Appliance width in mm	595
Appliance height in mm	456
Appliance depth in mm	568
Weight in kg	38.0
Total rated load in kW	3.2
Voltage in V	220-240
Number of phases	1
Fuse rating in A	16
Length of supply lead in m	2
<b>Standard accessories</b>	
Baking and roasting rack with PerfectClean	1
Glass tray	2

H 7840 BM

Speed oven

with a seamless design, Automatic programmes and food probe

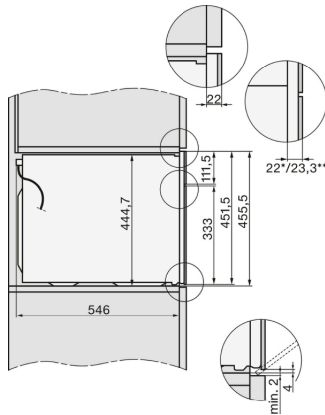

H7x40BM/BMX, installation drawings

22 mm - glass  
23,3 mm - metal

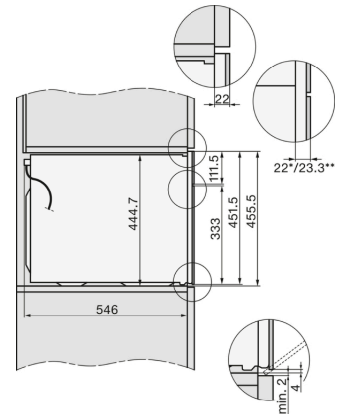

H7x40BM/BMX, installation drawings, GB, AUS

22 mm - glass  
23,3 mm - metal

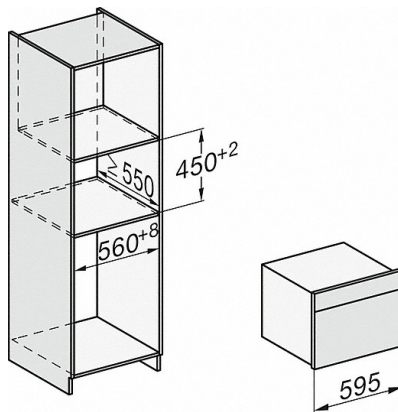

H7x40BM/BMX, installation drawings

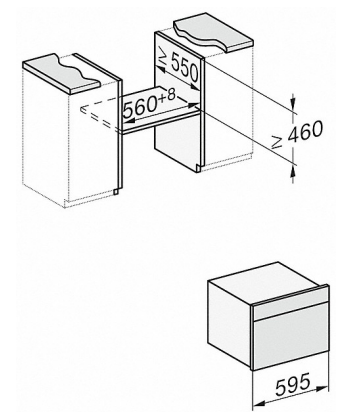

H7x4xBM, installation drawings

If the oven is to be installed under a hob, follow the instructions for installing the hob and the height of the hob.

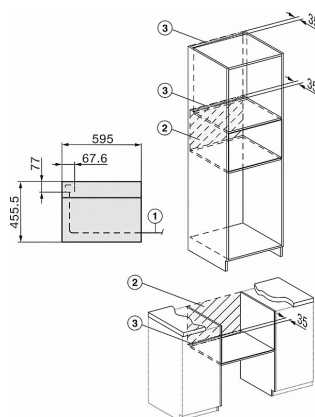

H7x40BM/BMX, installation drawings, GB, AUS

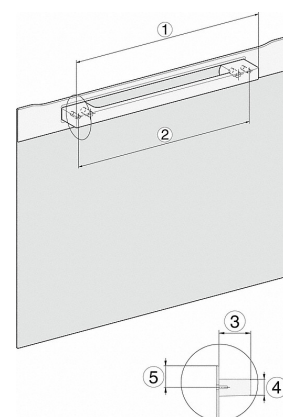

DG2840, DG7x40, DGC7x4x, DG7x6x, DGC7x6x, DGD7635, DGM7x4x, DO7, H28B/BP, H7x4xB/BM/BP,

H 7840 BM

Speed oven

with a seamless design, Automatic programmes and food probe

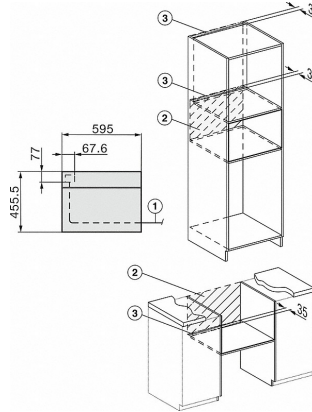

- 1) Mains connection cable, L=2000 mm
- 2) No connection in this area
- 3) Lüftungsausschnitt min. 150 cm<sup>2</sup>

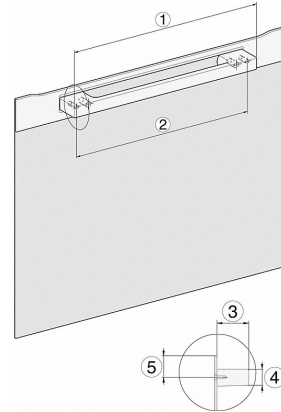

H7x6xB/BP, installation drawing

- 1) 400 mm
- 2) 360 mm
- 3) 47 mm
- 4) 24 mm
- 5) 32.5 mm

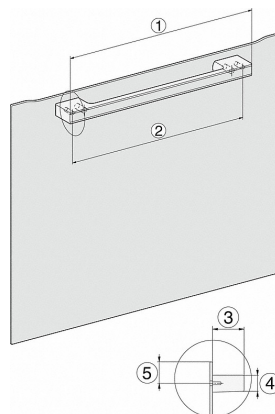

DG7x40, DGC7x4x, DGC7x6x, DG7635, DGM7x4x, DO7, H2860B/BP, H7240BM, H7x40BM, H7x4xB/BP, H7x6xB/BP, installation drawings

- 1) 400 mm
- 2) 360 mm
- 3) 47 mm
- 4) 27 mm
- 5) 32.5 mm

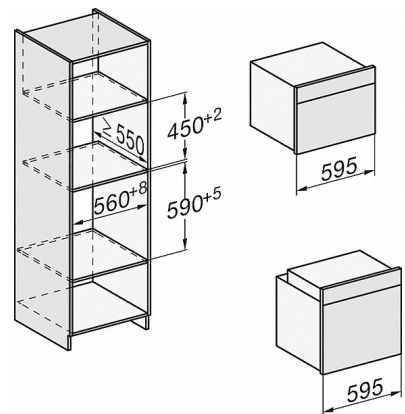

H226x-1B/BP/E/EP/IP, H2760B/BP, H28x0B/BP, H7x40BM/BMX, H7x6xB/BP/BPX, installation drawings

H 7840 BM

Speed oven

with a seamless design, Automatic programmes and food probe

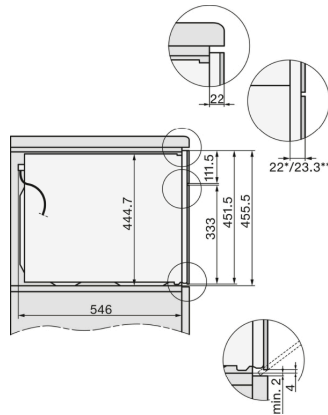

H7x40BM/BMX, installation drawings, GB, AUS

22 mm - glass  
23.3 mm - metal

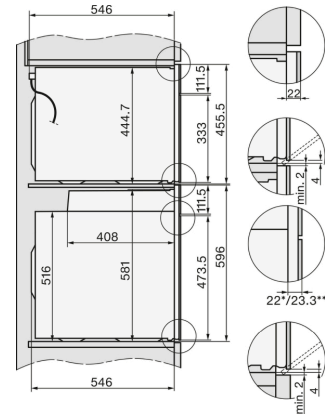

H2xxx-1 B/BP/E/I/IP, H7xxx B/BP/BM/BMX, installation drawings

22 mm - glass  
23,3 mm - metal

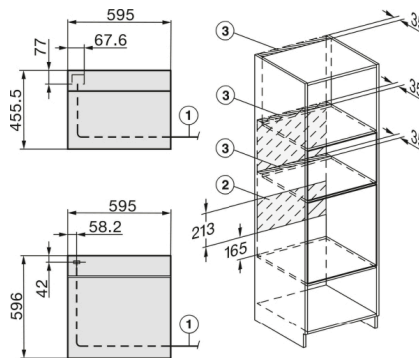

H2xxx-1 B/BP/E/I/IP, H7xxx B/BP/BM/BMX, installation drawings

22 mm - glass  
23,3 mm - metal