

F 2671 Vi MasterCool Freezer



- Push2Open
- No Frost
- Ice/Water Dispenser
- Brilliant Light
- 3 star Energy Rating

Appliance category	
Refrigerator/Freezer/Fridge-freezer	-/•/-
Construction type	
Built-in appliance: integrated	•
Door hinge side/Convertible hinging/Can be installed side-by-side	Left/-/•
Design	
Interior colour	Metallic look
Refrigerator/Freezer compartment lighting	-/-
User convenience	
Freshness system	-
IceMaker with mains water connection/Ice/Water dispenser	-/•
DuplexCool Pro/DynaCool/NoFrost	-/-/•
SelfClose/SlidingShelf/Active AirClean filter	-/-/-
Door design	Push2Open/Pull2Open
Temperature range	-14°C to -24°C
FullAccess/EasyClean/MaxLoad hinges	•/•/•
Controls	
Operating concept	MasterSensor
SuperCool/SuperFreeze/Sabbath mode	-/•/•
No. of temperature zones	1
Fridge section	
No. of shelves	-
Number of vegetable drawers/crisper drawers	-/-
Door shelf for jars/bottles	-/-
Freezer section	
Number of shelves/Number of freezer drawers	2/2
Door baskets – small/large	-/-
Efficiency and sustainability	
Energy efficiency rating	3
Annual energy consumption (kWh/year)	-/-
Appliance networking	
Miele@home/WifiConn@ct/MobileControl	•/•/•
Accessories required	-
Safety	
Lock function	•
Audible door alarm/Audible temperature alarm	•/•
Optical door alarm/Optical temperature alarm	•/•
Technical data	
Niche dimensions in mm (W x H x D)	610 x 2134 – 2164 x 629
Appliance dimensions in mm (W x H x D)	603 x 2127 x 629
Weight in kg/Load bearing capacity of floor	152/348
Maximum fridge/freezer section door-front weight in kg	-/68
Maximum fridge/freezer section door-front thickness in mm	-/38
Fridge zone/incl. MasterFresh zone/freezer zone in l	-/-/359
Total usable capacity in l	359
Storage time in case of fault/Freezing capacity in kg	-/-
Sound power in dB(A) re1pW	42
Voltage	220 – 240
Length of supply lead in m	3.0

F 2671 Vi MasterCool Freezer

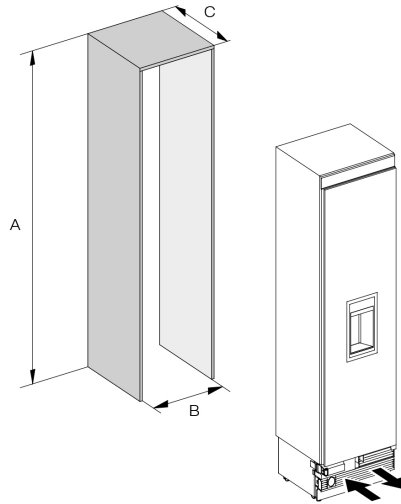

1.

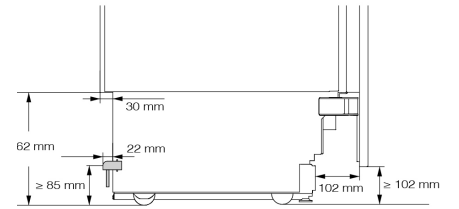

2.

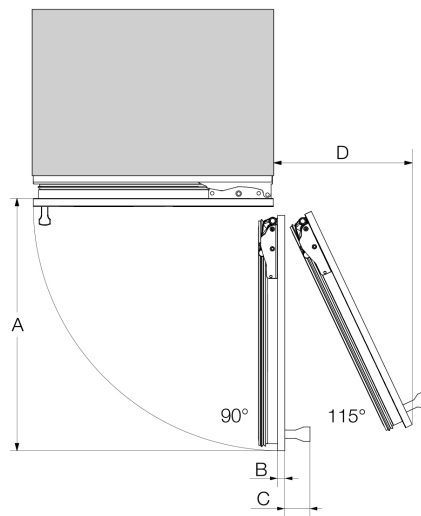

3.

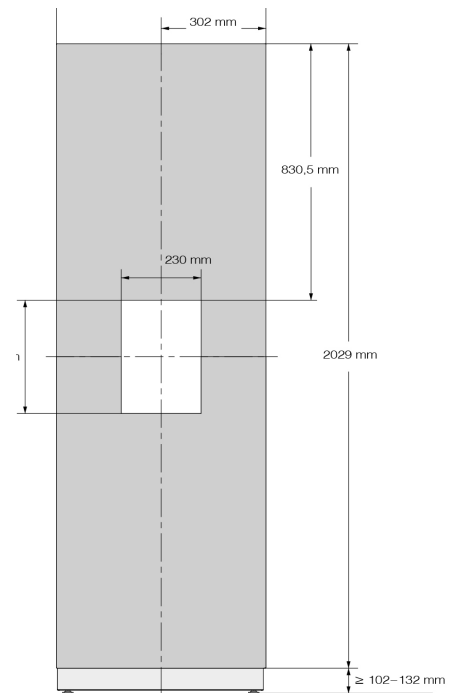

F 2671 Vi- (Installation drawing)

- 1. Side
- 2. Above
- 3. Front